



Installation Manual

Onan Generator Set for Commercial Mobile

HDKAG (Spec A–K)

Table of Contents

Safety Precautions	iii
1. Introduction	1-1
INSTALLATION CODES AND SAFETY RECOMMENDATIONS	1-1
2. Specifications	2-1
3. Installation Outline	3-1
INTRODUCTION	3-1
PREPARATION	3-1
COMPARTMENT MOUNTING	3-2
CONNECTING TO VEHICLE SYSTEMS	3-4
EXHAUST SYSTEMS	3-6
4. Mounting	4-1
LOCATION	4-1
COMPARTMENT MOUNT	4-1
5. Ventilation and Acoustics	5-1
6. Exhaust System	6-1
GENERAL	6-1
MUFFLER RECOMMENDATIONS	6-1
EXHAUST INSTALLATION GUIDELINES	6-1
TAILPIPE RECOMMENDATIONS	6-2
ALTERNATE EXHAUST INSTALLATIONS	6-3
7. Cooling System	7-1
COOLANT RECOVERY TANK	7-1
8. Fuel System	8-1
BIO-DIESEL FUELS B5 – B20	8-2
9. Electrical Connections	9-1
GENERAL	9-1
CONDUIT	9-1
WIRING DISCONNECT	9-2
LINE CIRCUIT BREAKERS	9-2
LOAD CONNECTIONS	9-2
REMOTE CONTROL CONNECTIONS	9-6
STARTING BATTERY	9-7
INSTALLATION OF GENERATORE SET CONTROL BOX	9-9
10. Initial Start and Checks	10-1
INSTALLATION REVIEW	10-1

Table of Contents

INITIAL STARTING AND CHECKS	10-3
11. Wiring Diagrams	11-1

Safety Precautions

Before operating the generator set, read the Operator's Manual and become familiar with it and the equipment. **Safe and efficient operation can be achieved only if the unit is properly operated and maintained.** Many accidents are caused by failure to follow fundamental rules and precautions.

The following symbols, found throughout this manual, alert you to potentially dangerous conditions to the operator, service personnel, or the equipment.

⚠ DANGER *This symbol warns of immediate hazards which will result in severe personal injury or death.*

⚠ WARNING *This symbol refers to a hazard or unsafe practice which can result in severe personal injury or death.*

⚠ CAUTION *This symbol refers to a hazard or unsafe practice which can result in personal injury or product or property damage.*

FUEL AND FUMES ARE FLAMMABLE

Fire, explosion, and personal injury can result from improper practices.

- Do not smoke or allow an open flame or spark producing equipment near the generator set or fuel tank.
- Fuel lines must be adequately secured and free of leaks. Fuel connection at the engine should be made with an approved flexible, non-conductive line.

GASOLINE AND LPG FUEL MAY BE ACCIDENTALLY IGNITED BY ELECTRICAL SPARKS, presenting the hazard of fire or explosion, which can result in severe personal injury or death. When installing the generator set:

- Keep electrical and fuel lines as far apart as possible. Do not allow contact unless both lines are sheathed.

EXHAUST GASES ARE DEADLY

- Never occupy the vehicle with the generator set running unless the vehicle is equipped with an operating carbon monoxide detector.
- Prior to every startup and after eight hours of running, all carbon monoxide detectors must be tested and confirmed to be working in accordance with the manufacturer's instructions or owners manual.
- Provide an adequate exhaust system to properly expel discharged gases. Do not use engine cooling air to heat a compartment.
- Be sure the unit is well ventilated.

MOVING PARTS CAN CAUSE SEVERE PERSONAL INJURY OR DEATH

- Before starting work on the generator set, disconnect batteries. This will prevent accidental starting and electrical arcs. Disconnect the Negative (-) battery cable first to reduce the risk of arcing.
- Keep your hands away from moving parts.
- Make sure that fasteners on the generator set are secure. Tighten supports and clamps, keep guards in position over fans, drive belts, etc.
- Do not wear loose clothing or jewelry while working on generator sets. Loose clothing and jewelry can become caught in moving parts. Jewelry can short out electrical contacts and cause shock or burning.
- If adjustment must be made while the unit is running, use extreme caution around hot manifolds, moving parts, etc.

ELECTRICAL SHOCK CAN CAUSE SEVERE PERSONAL INJURY OR DEATH

- Disconnect the negative (-) cable at the starting battery before removing protective shields or touching electrical equipment. Use rubber insulative mats placed on dry wood platforms on the ground or over floors that are metal or concrete when around electrical equipment. Do not wear

damp clothing (particularly wet shoes) or allow skin surfaces to be damp when handling electrical equipment.

- Use extreme caution when working on electrical components. High voltages can cause injury or death.
- Follow all state and local electrical codes. Have all electrical installations performed by a qualified electrician. Tag open switches to avoid accidental closure.
- **DO NOT CONNECT GENERATOR SET DIRECTLY TO ANY BUILDING ELECTRICAL SYSTEM.** Hazardous voltages can flow from the generator set into the utility line. This creates a potential for electrocution or property damage. Connect only through an approved device and after building main switch is open. Consult an electrician in regard to emergency power use.

GENERAL SAFETY PRECAUTIONS

- Wear safety glasses and protective clothing when servicing batteries. **DO NOT SMOKE** while

servicing batteries. Lead acid batteries emit a highly explosive hydrogen gas that can be ignited by electrical arcing or by smoking.

- Have a fire extinguisher rated ABC nearby. Maintain extinguisher properly and become familiar with its use.
- (Gasoline sets) Benzene and lead, found in some gasoline, have been identified by some state and federal agencies as causing cancer or reproductive toxicity. When checking, draining or adding gasoline, take care not to ingest, breathe the fumes, or contact gasoline.
- Used engine oils have been identified by some state or federal agencies as causing cancer or reproductive toxicity. When checking or changing engine oil, take care not to ingest, breathe the fumes, or contact used oil.
- Do not work on this equipment when mentally or physically fatigued, or after consuming any alcohol or drug that makes the operation of equipment unsafe.

1. Introduction

This manual shows how to install the HDKAG 10 kW diesel generator set. The generator set must be installed properly to operate reliably, quietly, and safely. **Read the entire manual before starting installation.**

See the Operator's Manual (981-0137) for operation and maintenance instructions.

These subjects are covered in this manual. Consider **all** these requirements before installing the set.

- Level and supportive mounting surface
- Adequate cooling air
- Adequate fresh induction air
- Discharge of circulated air
- Noise levels
- Accessibility for maintenance and service
- Exhaust connections
- Fuel supply
- Electrical connections

INSTALLATION CODES AND SAFETY RECOMMENDATIONS

When properly installed, this generator set meets or exceeds these codes:

- National Electrical Code, NFPA 70-Article 551
- ANSI/RVIA EGS-1 - 1986, Generator Set Standard
- ANSI A119.2/NFPA 501C Standard for Recreational Vehicles
- CSA Electrical Bulletin 946

The vehicle builder and/or the set installer must comply with all local codes that apply to generator set installation. The generator set installer bears sole responsibility for the selection of the appropriate generator set, installation design, and installation.

The following Installation Codes and Safety Recommendations apply to the installation and operation of generator sets in RVs and in commercial vehicles. The address of each agency is listed so that copies of the codes may be obtained. Installation codes and recommendations are subject to change, and may vary by location or over time. **The vehicle manufacturer and the generator set installer bear sole responsibility for following all applicable codes and regulations.**

1. ANSI-A119.2 FMVSS 301 Recreational Vehicle Industry Association
14650 Lee Road
Chantilly VA 22021
2. NFPA 70 (N.E.C.) NFPA-501C National Fire Protection Association
470 Atlantic Avenue
Boston MA 02210
3. CSA Electrical Bulletin #946 Canadian Standards Association, Housing and Construction Materials Section
178 Rexdale Blvd.
Rexdale, Ontario,
Canada M9W 1R3
4. California Administrative Code - Title 25 Chapter 3 State of California Documents Section
P.O. Box 1015
North Highlands, CA 95660

This manual contains information that is subject to change. For this reason, use only the installation manual supplied with the generator set for the installation.

 *WARNING* Incorrect installation, service, or replacement of parts can result in severe personal injury, death and/or equipment damage. Service personnel must be qualified to perform electrical and/or mechanical component installation.

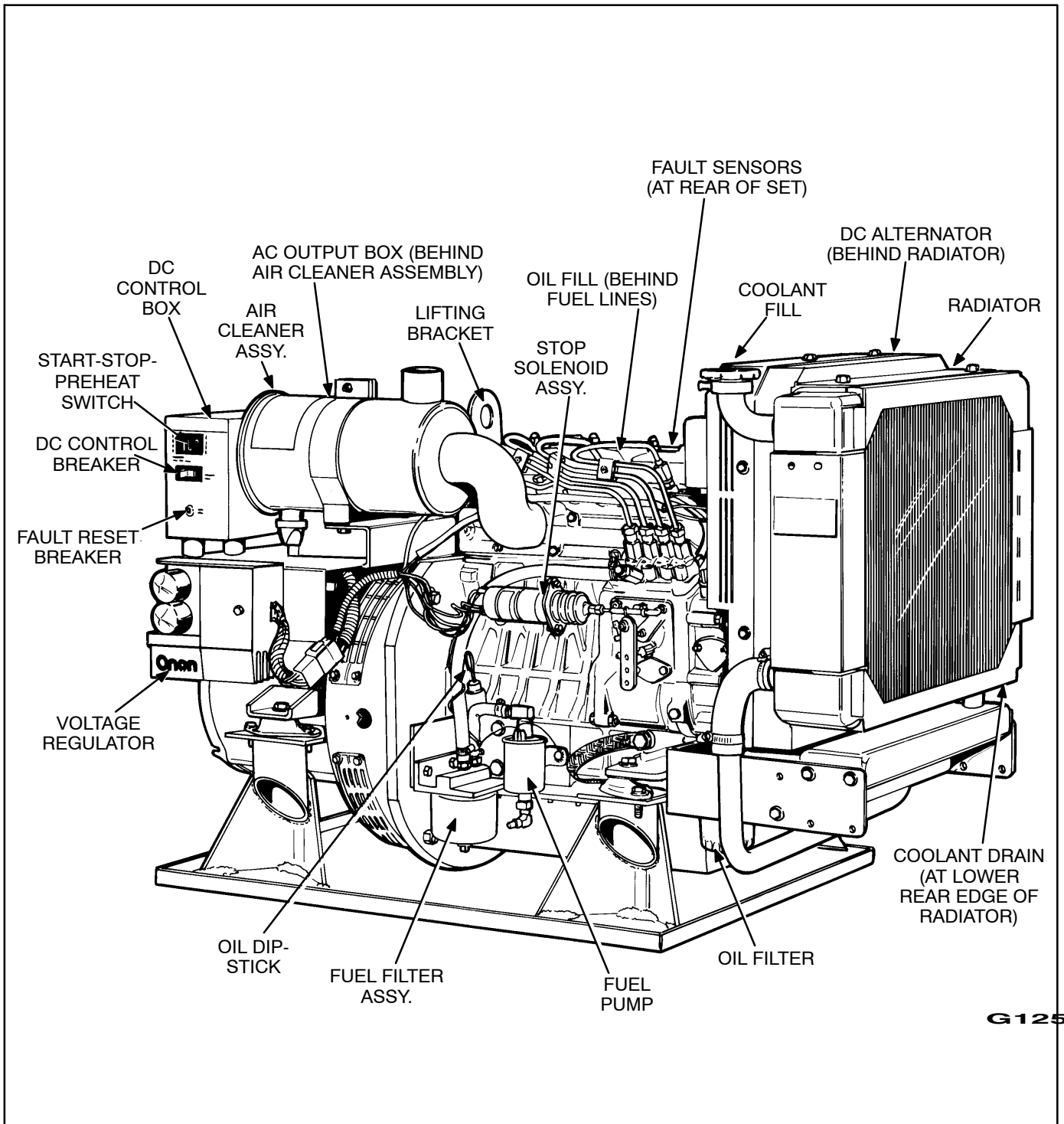

G1250s

FIGURE 1-1. HDKAG GENERATOR SET

THIS PAGE IS INTENDED TO BE BLANK

3. Installation Outline

INTRODUCTION

This section briefly describes the steps in a typical compartment-mount installation. The installer is responsible for complying with all applicable installation codes and safety requirements. This section includes:

- Preparation
- Compartment Mounting
- Connecting to Vehicle Systems
- Exhaust System

Refer to the detailed instructions that are given in each section, covering mounting, ventilation, fuel system, electrical connections, and exhaust system, for specific procedures and important safety precautions.

PREPARATION

1. Remove the wooden shipping crate by prying the bottom of the crate's sides and ends out from the wooden skid base. Carefully lift the crate off the generator set and discard.

Remove the plastic bag covering the generator set. Collect loose shipped items, such as the Operator's Manual, and add them to the vehicle documentation package.

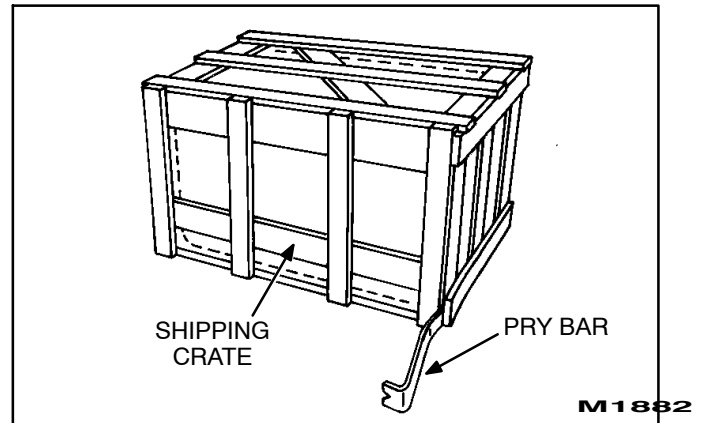

FIGURE 3-1. CRATE REMOVAL

2. Remove the mounting bolts that secure the wooden skid to the generator set base.

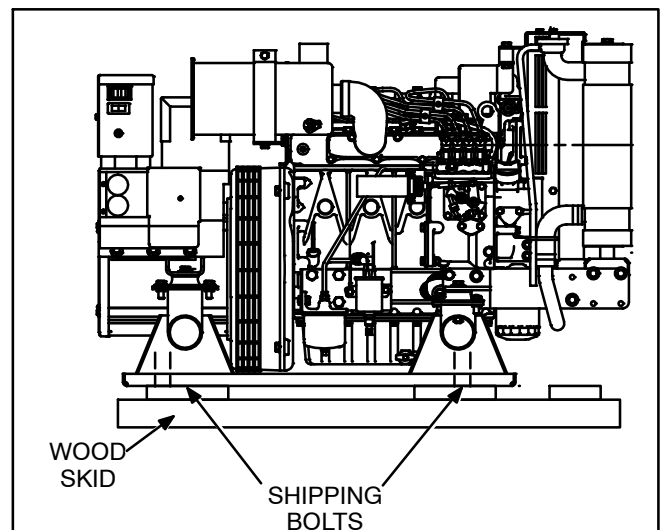

FIGURE 3-2. SKID BASE REMOVAL

COMPARTMENT MOUNTING

Install the generator set in its own compartment. If any part of the compartment is above the vehicle floor, separate the compartment from the living quarters with vapor-tight walls. Refer to the *Mounting* section for compartment construction details.

⚠WARNING *Exhaust gases present the hazard of severe personal injury or death. Make the compartment walls vapor tight to the interior of the vehicle to prevent exhaust fumes from entering the living quarters.*

The generator set requires an unobstructed air inlet at the generator end of at least 347 square inches (2239 cm²). Refer to the *Mounting* and *Ventilation* section for details. Provide access to the set for maintenance. Provide space for removing the set either through the door or out the bottom of the compartment.

1. Carefully measure the compartment to provide proper clearance for the generator set. Figure 3-3 shows the compartment dimensions. Add 1/2 inch to the compartment depth if 1/2-inch insulation is used inside the door.

Adding one to two inches of extra space on the left side of the compartment will make electrical and fuel connections easier. See Figure 3-5.

2. Make holes in the bottom of the compartment for generator set mounting, air outlet and oil drain (Figure 3-4). If there is wood under the compartment, remove the section under the compartment and replace it with a sheet metal floor and an adequate steel support frame.

TABLE 3-1. COMPARTMENT DIMENSIONS AND CLEARANCES

<p>Clearances (approximate):</p> <p>Wall to drip pan (service side of set): 1 inch Clearance, wall to exhaust elbow (rear of set): 3 inches Clearance at top of set: 1 inch Clearance, wall to exhaust heat shield 1-1/2"</p>
<p>Compartment Dimensions (approximate):</p> <p>Height: 27 inches Depth: 25 inches (26.75" with mounted muffler) Width: 41-1/2 inches (standard 1-phase generator set) Width: 41-1/2, 42-1/2 or 44-1/2 inches (3-phase generator sets: see drawings in Section 4)</p>

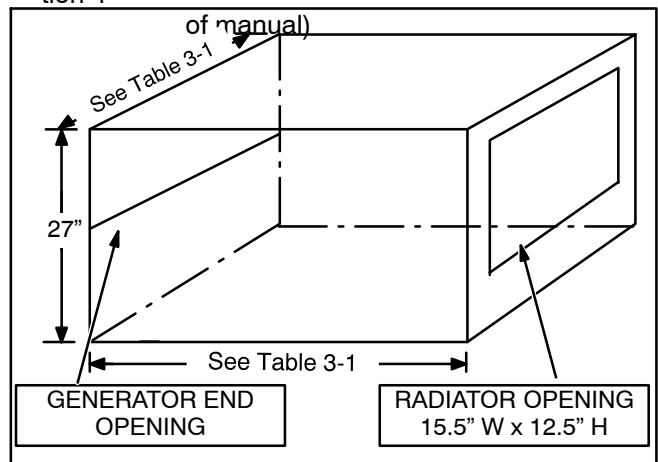

FIGURE 3-3. COMPARTMENT DIMENSIONS

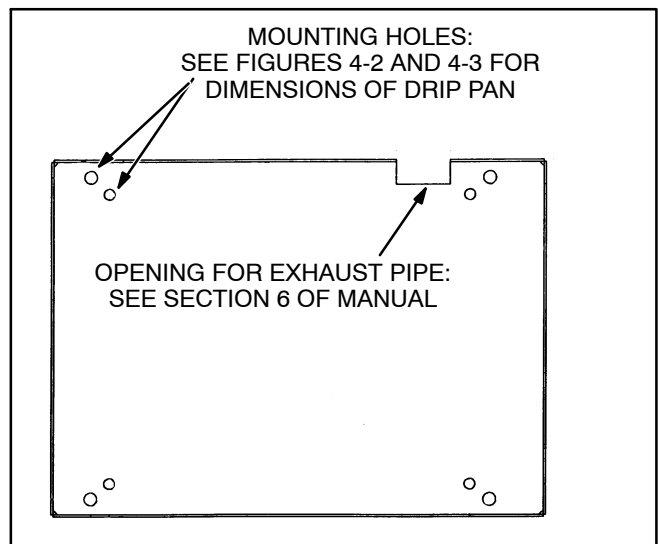

FIGURE 3-4. COMPARTMENT FLOOR MOUNTING HOLE PATTERN

- Put holes in the compartment to run connections for the fuel line, battery cable, remote control harness and AC conduit. Design holes so they will not chafe or restrict the lines.

If the remote control harness or AC conduit go directly into the interior of the vehicle, seal around the wires and inside the conduit to prevent the passage of exhaust gases. The fuel line must not be routed through the interior of the vehicle.

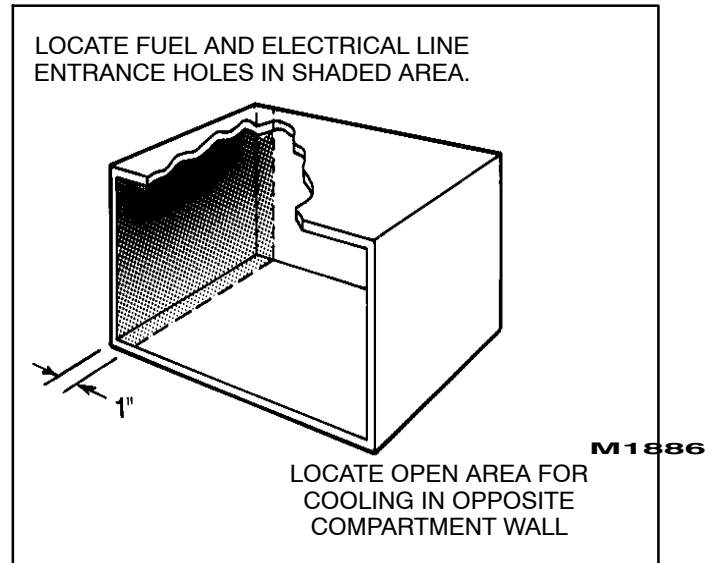

FIGURE 3-5. generator set TO VEHICLE SYSTEMS CONNECTIONS

- Mount the generator set in the compartment with four 1/2" diameter bolts and nuts. Screw length must not protrude more than 1/2-inch (13 mm) through the generator set base (Figure 3-6).
- Proceed to Connecting To Vehicle Systems (page 3-4).

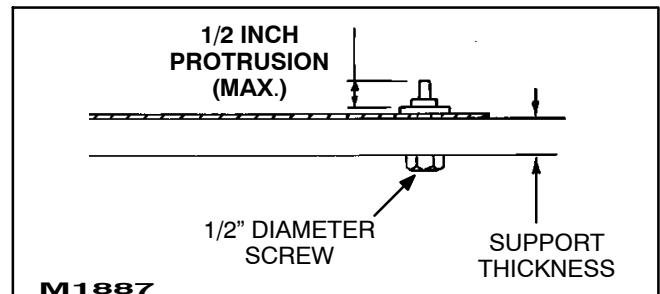

FIGURE 3-6. COMPARTMENT MOUNTING

CONNECTING TO VEHICLE SYSTEMS

1. Route fuel line separate from electrical wires or separate them with conduit or other sheathing.

⚠WARNING *Fuel presents the hazard of fire or explosion that can result in severe personal injury or death. Do not smoke or allow any flame, spark, pilot light, arc-producing equipment or other ignition sources near fuel or in the installation area. Read the important safety precautions in the Fuel Systems section.*

2. Use fuel hose fittings with 1/8-27 NPT female connectors for fuel tank pickup line (to fuel pump) and return line (from injectors). Use protective sleeving over frame rails. Protect holes with rubber grommets. Secure fuel line every 18 inches. Connect the fuel lines to bulkhead connectors. Do not “tee” into existing fuel lines used for vehicle propulsion engine operation. Doing this may restrict fuel delivery to the generator set.

3. Connect the fuel lines to bulkhead connectors at the compartment, or protect them where they leave the compartment. Direction of fuel tank fittings must be adjusted during connection of fuel lines to prevent kinks or sharp bends.

4. Install a listed 1/2-inch flexible watertight conduit over the AC wiring. Secure the conduit to the fitting on the generator set.

⚠WARNING *Accidental starting of the generator set can cause severe personal injury or death. Do not connect the battery cables to the generator set starting battery until instructed to in the Initial Start and Checks section.*

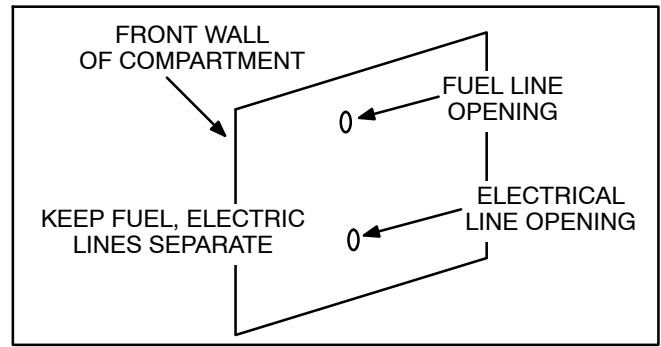

FIGURE 3-7. FUEL AND ELECTRIC LINES

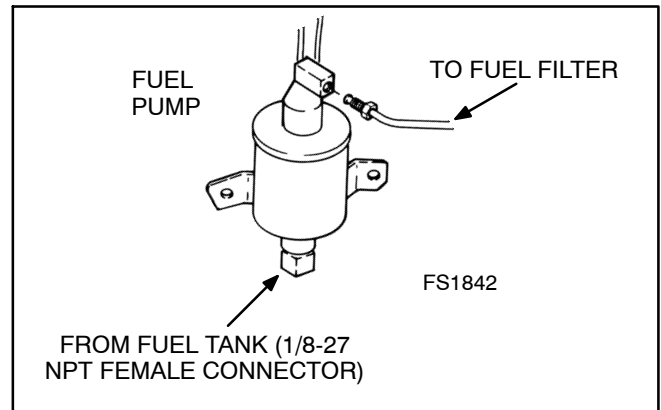

FIGURE 3-8. FUEL LINE CONNECTION

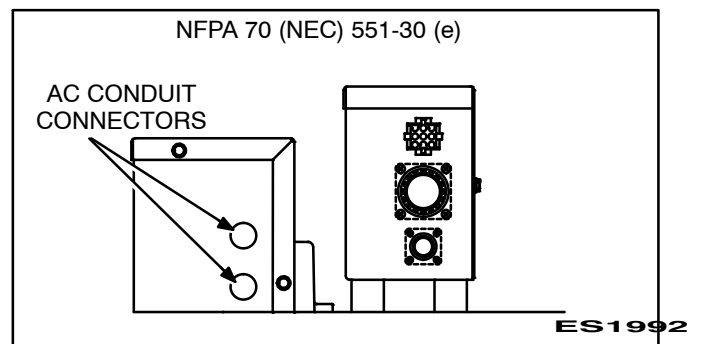

FIGURE 3-9. AC CONDUIT CONNECTION

5. Route the battery positive (+) cable through an access hole in the compartment. Connect the battery positive (+) cable to the B+ connection on the start solenoid.

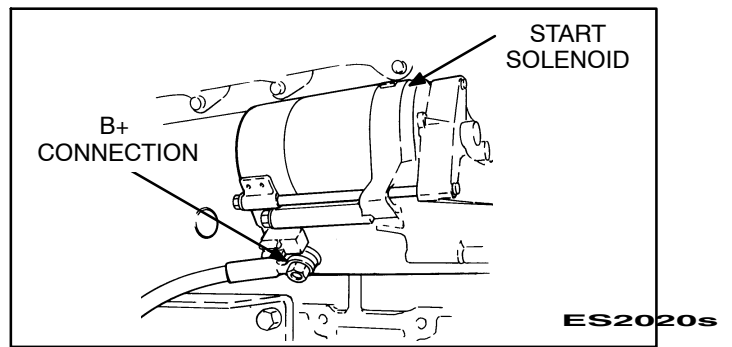

FIGURE 3-10. BATTERY POSITIVE (+) CONNECTION

6. Connect the battery negative (-) cable to a hole in the engine block as shown. A recommended connection for the negative cable is to one of the control box mounting bolts (see Figure 6-2 for location).

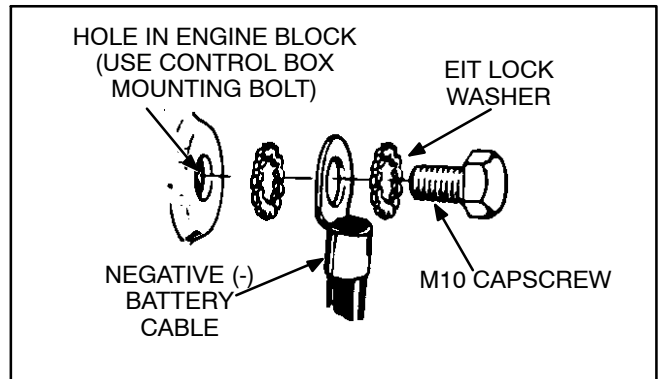

FIGURE 3-11. BATTERY NEGATIVE (-) CONNECTION

7. Route the remote control connector through an opening in the compartment. Connect the remote control connector to the mating connector on the DC control box.
8. Proceed to the next section on connecting the exhaust system.

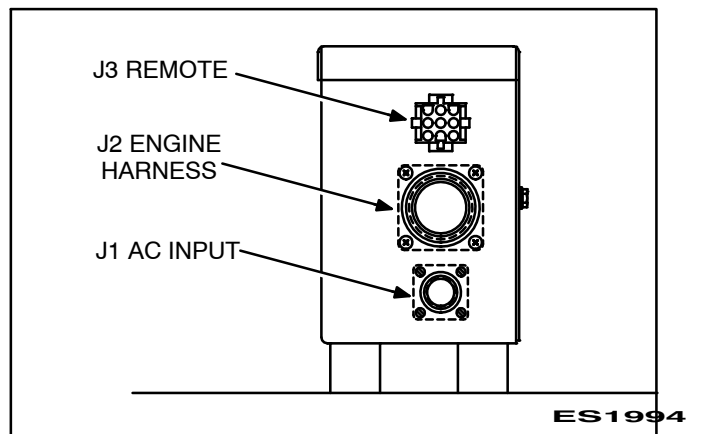

FIGURE 3-12. REMOTE CONTROL CONNECTION

EXHAUST SYSTEMS

⚠WARNING Exhaust gas presents the hazard of severe personal injury or death. Do not terminate the exhaust pipe under the vehicle. The exhaust pipe must not terminate so that any vent, window, or opening into the living area is within the triangular area shown in Figure 3-21. Read the important safety precautions in the Exhaust Systems section.

1. Connect the exhaust pipe (1.5-inch I.D., installer-supplied) to the generator set as shown in Figure 3-13.

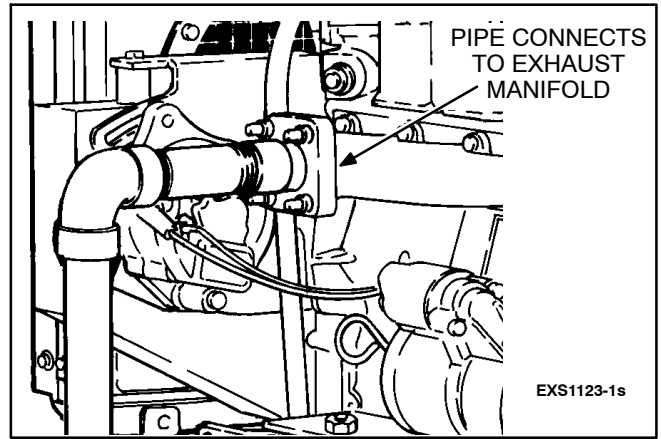

FIGURE 3-13. EXHAUST PIPE CONNECTION

2. Do not terminate the exhaust tail pipe under the vehicle. The exhaust tail pipe must terminate 1 inch (25.4 mm) beyond the side or end of the vehicle (Figure 3-14).

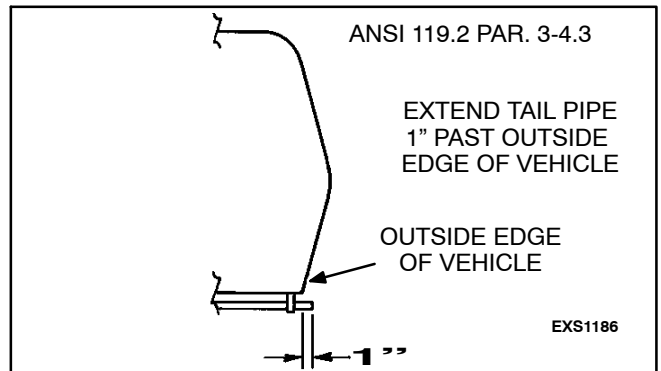

FIGURE 3-14. TAIL PIPE EXTENSION BEYOND VEHICLE

3. Support the tail pipe as close to the outside of the vehicle as possible (Figure 3-15).

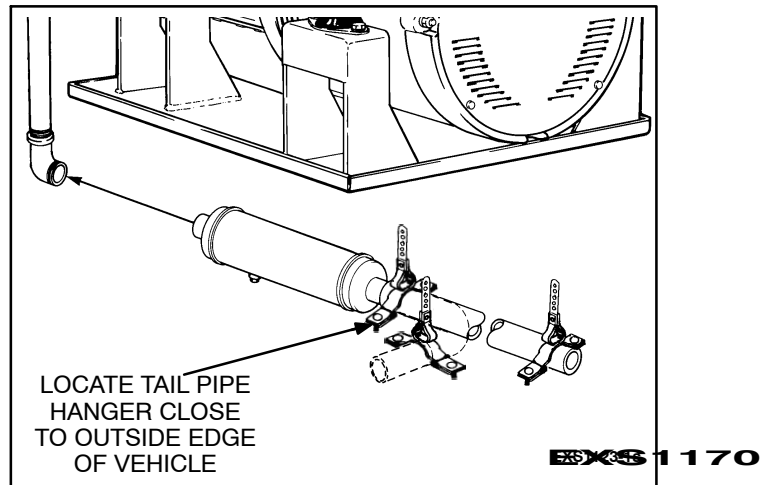

FIGURE 3-15. EXHAUST PIPE SUPPORT

- Termination of the exhaust tail pipe below the angle of departure (lowest point on rear of vehicle to the tire ground contact point) must be protected by a skid bar, trailer hitch, or some frame member (Figure 3-16).

⚠WARNING *Tailpipe must be protected by skid bar or other structure. If tailpipe is accidentally bent or crushed, exhaust gases might not be able to escape, and may be drawn into the living quarters of the vehicle, causing severe personal injury or death.*

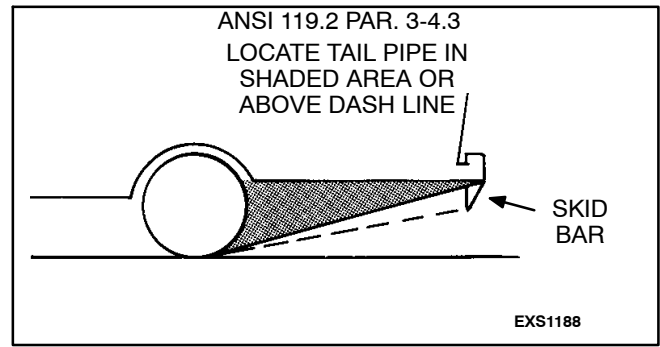

FIGURE 3-16. TAIL PIPE PROTECTION

- Be aware that any vent, window, or opening that can be opened and that is not permanently sealed from the vehicle living space or work area, can be an avenue for carbon monoxide.

The tail pipe must not terminate so that any vent, window, or opening into the living area is within the triangular area shown in Figure 3-17.

- Refer to each of the sections in this manual for detailed installation instructions and for important safety precautions. Always follow the procedures in the Initial Start and Checks section when the installation is complete.

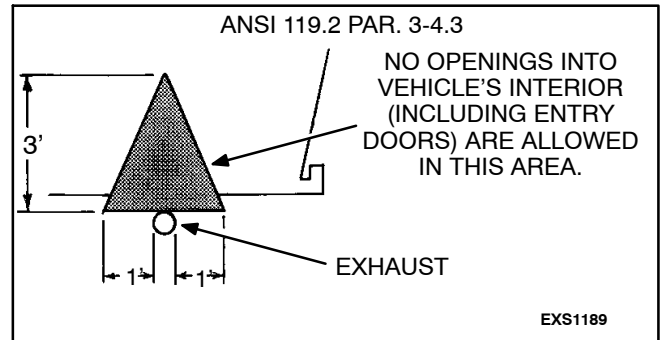

FIGURE 3-17. TAIL PIPE LOCATION

THIS PAGE IS INTENDED TO BE BLANK

4. Mounting

LOCATION

The generator set location must be well ventilated, insulated, close to the fuel supply and close to the center of electrical load distribution. These conditions may be in the same room or compartment as the vehicle propulsion engine. However, a generator set cannot be installed in the propulsion engine compartment unless specific conditions are met.

⚠WARNING *Do not install a diesel generator set in the same room or compartment as a gasoline engine or generator set. Gasoline fire or explosion can result in severe personal injury or death. The diesel unit may not be ignition protected and can ignite gasoline fumes, causing severe personal injury or death.*

Select a location that will allow adequate space on all sides for ventilation and servicing the set. On RV installations, keep the generator set away from living quarters.

COMPARTMENT MOUNT

The HDKAG generator set is designed for above-floor compartment mounting. The vehicle frame must support the weight of the generator set (approximately 520 pounds [235.9 kg] for the standard single-phase version). Mounting hole locations are shown in Figures 4-1 and 4-2. Install two through-bolts to the drip pan on both sides of the generator set. Tighten the bolts securely to the mounting base with bolts and flat washers. **The vehicle manufacturer and the installer must provide a structurally sound support frame.**

Construct the generator set compartment according to the safety-approved specifications listed in Section 1 of this manual. Figures 4-3 and 4-4 show generator set dimensions.

There is one inch (25 mm) minimum clearance between the set and compartment insulation. Minimum space between the engine exhaust components and compartment insulation is 3 inches (76 mm).

If the compartment is large in size, allow extra space at the generator end. Use a foam gasket at

the radiator to prevent recirculation of air through the radiator.

When constructing the generator set compartment, allow for airflow restrictions caused by duct work and grilles. To purge the compartment of hot air, the air openings' position must permit airflow while the set is running. On shutdown, the openings must allow hot air to escape the compartment.

Make the access opening large enough to remove the set, with openings at the ends of the compartment for engine and generator cooling air. An engine fan and a generator fan cool the set. The engine fan pushes air through the radiator. (A suction fan is optional for under-hood installations.) A centrifugal blower mounted on the generator drive disc draws generator cooling air into the end bell and discharges it at the blower outlet. See the *Ventilation* section of this manual for more details.

Allow extra clearance to access the following components:

- Oil fill
- Oil drain
- Oil filter
- Oil dipstick
- Air cleaner
- Start/Stop switch
- Circuit breaker
- DC fuse
- Coolant drain
- Coolant fill

Mount the coolant recovery tank (part of the accessory package) so coolant can be added easily, but make sure that the tank top is not above the radiator. Hoses are connected similarly, as shown in Figure 7-1.

Compartment Construction

1. Construct a vapor-tight wall to separate the compartment area from the living quarters or work area and the fuel supply. See Figures 4-3 and 4-4 for generator set dimensions.
2. Line the compartment walls with 26-gauge galvanized steel or a material of comparable strength and fire resistance (see NFPA 70, NEC and California Title 25 for complete details).

⚠WARNING *Exhaust gases present the hazard of severe personal injury or death. Make the compartment walls vapor-tight to the interior of the vehicle to prevent exhaust fumes from entering.*

3. Construct the compartment floor to prevent oil, fuel or water from accumulating.

⚠WARNING *Fuel and oil leakage is a fire hazard that can cause serious personal injury or death. Do not position the muffler directly below the drain hole.*

Do NOT use absorbent soundproofing material on the compartment floor. The floor should have as few openings as possible, to reduce the noise level.

4. Make holes or other provisions for diesel fuel supply and return lines to the compartment, and for the exit of the breather hose and the exhaust plumbing. See the *Fuel System* and *Exhaust System* sections of this manual for guidance and code references.
5. Install an approved junction box for connecting generator and load leads. See the *Electrical* section of manual for guidance and code references.

If the compartment penetrates the vehicle floor, be sure all joints and corners of the compartment are

vapor-tight to the interior. Seal all joints and bolts to prevent entrance of exhaust gas.

⚠WARNING *Exhaust gases are deadly. Inhalation of exhaust gas can result in severe personal injury or death. Be sure the compartment is sealed tightly to prevent entrance of deadly exhaust gas into the vehicle coach.*

To minimize noise, line the entire generator set compartment (except the compartment floor) with a 1/2 to 1 inch (12.7 to 25.4 mm) thickness of self-extinguishing acoustical material, rated for 250°F (121° C) minimum. Adjust the compartment height, width and depth dimensions to fit the acoustical material. See Figures 4-1 and 4-2 for drip pan dimensions.

A combination of materials works better than a single material to reduce noise. For example, composite materials are more effective than foam alone. Insulation must not reduce the minimum clearances specified in Figures 4-3 and 4-4, to meet ANSI and CSA insulation temperature rise limits for recreational vehicles.

⚠WARNING *Hot engine parts can ignite some insulation materials if too close, resulting in fire which can cause severe personal injury or death. Insulation must not reduce the specified minimum clearances.*

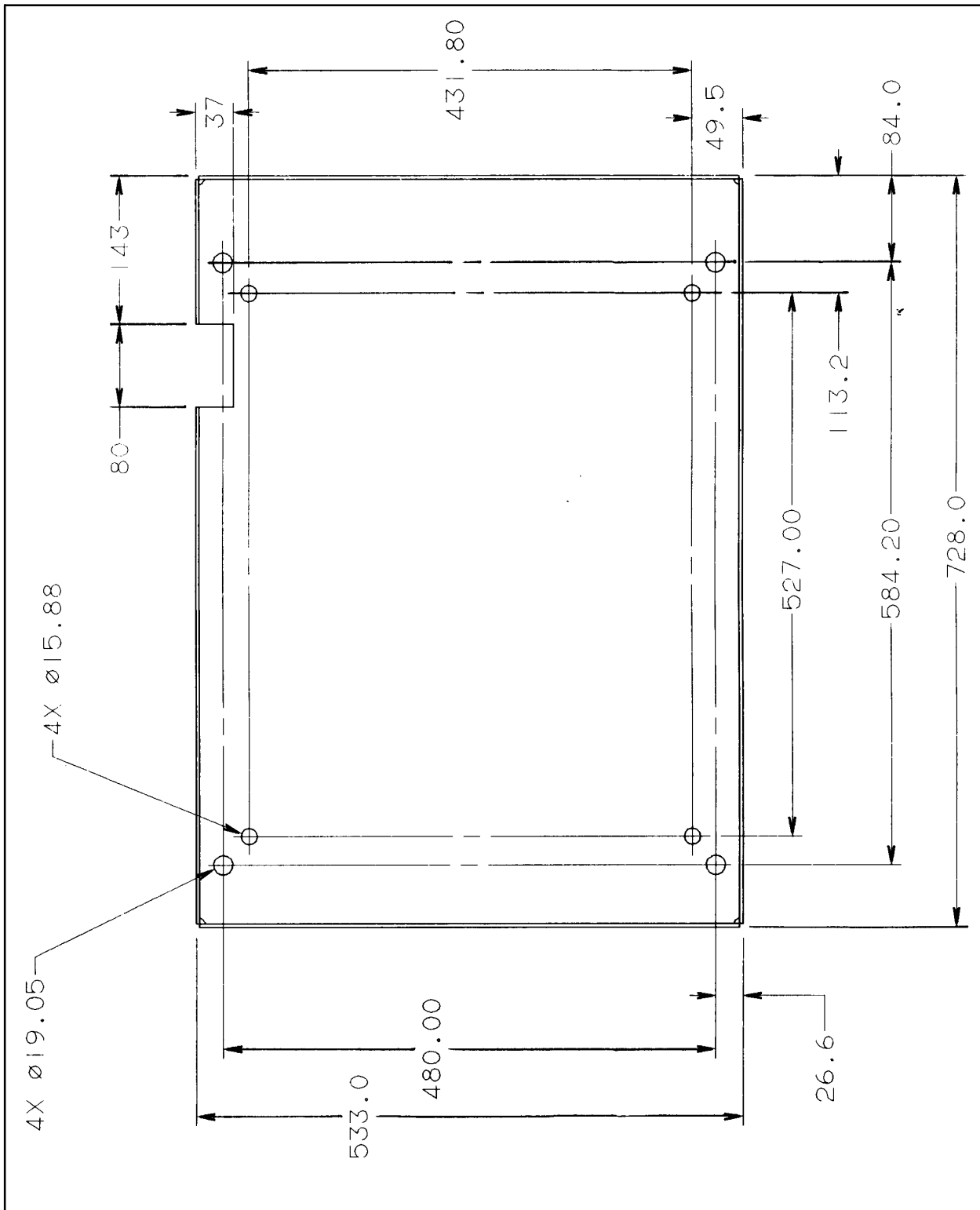

FIGURE 4-1. HDKAG DRIP PAN DIMENSIONS (SINGLE-PHASE)
 (from 403-3516)

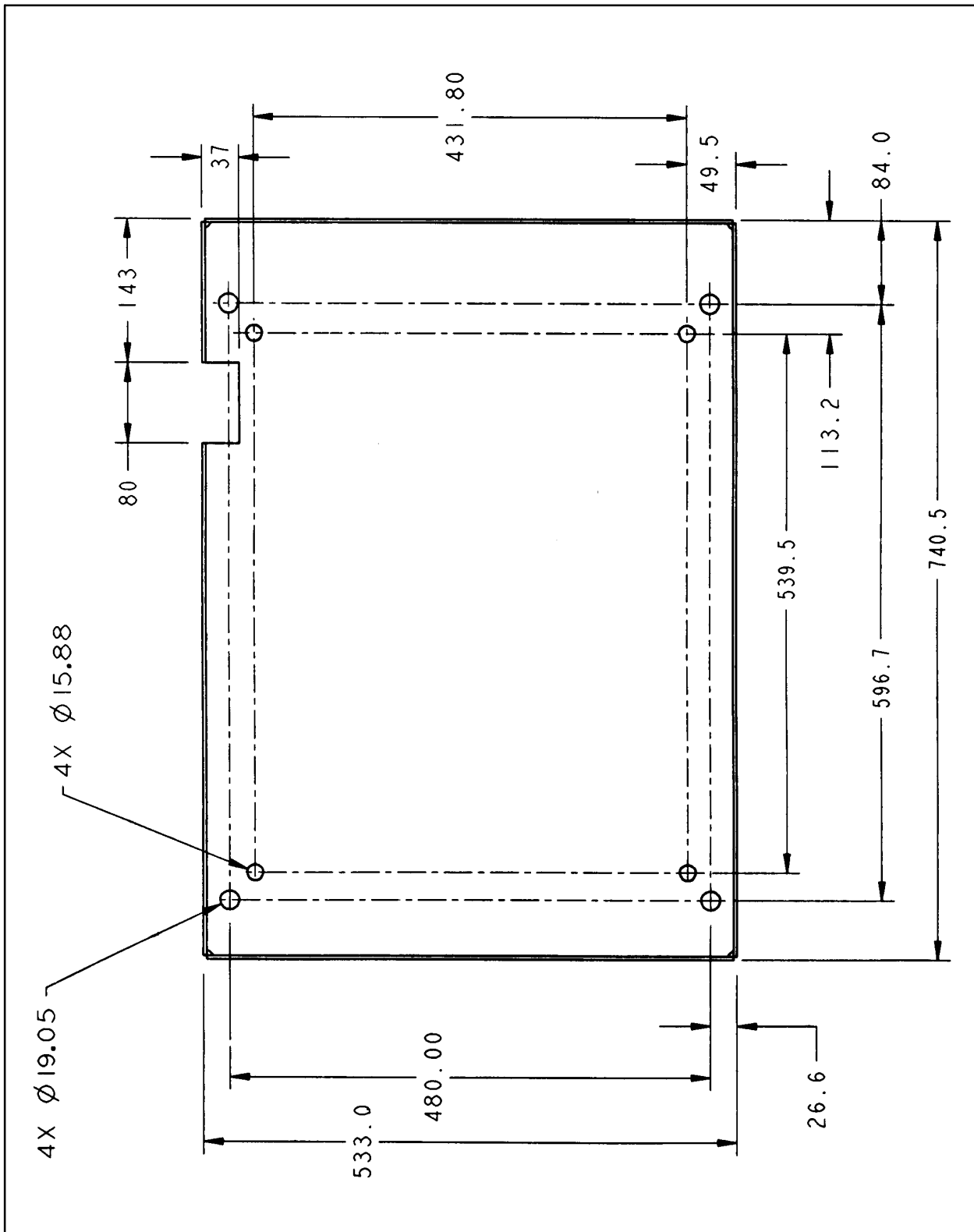
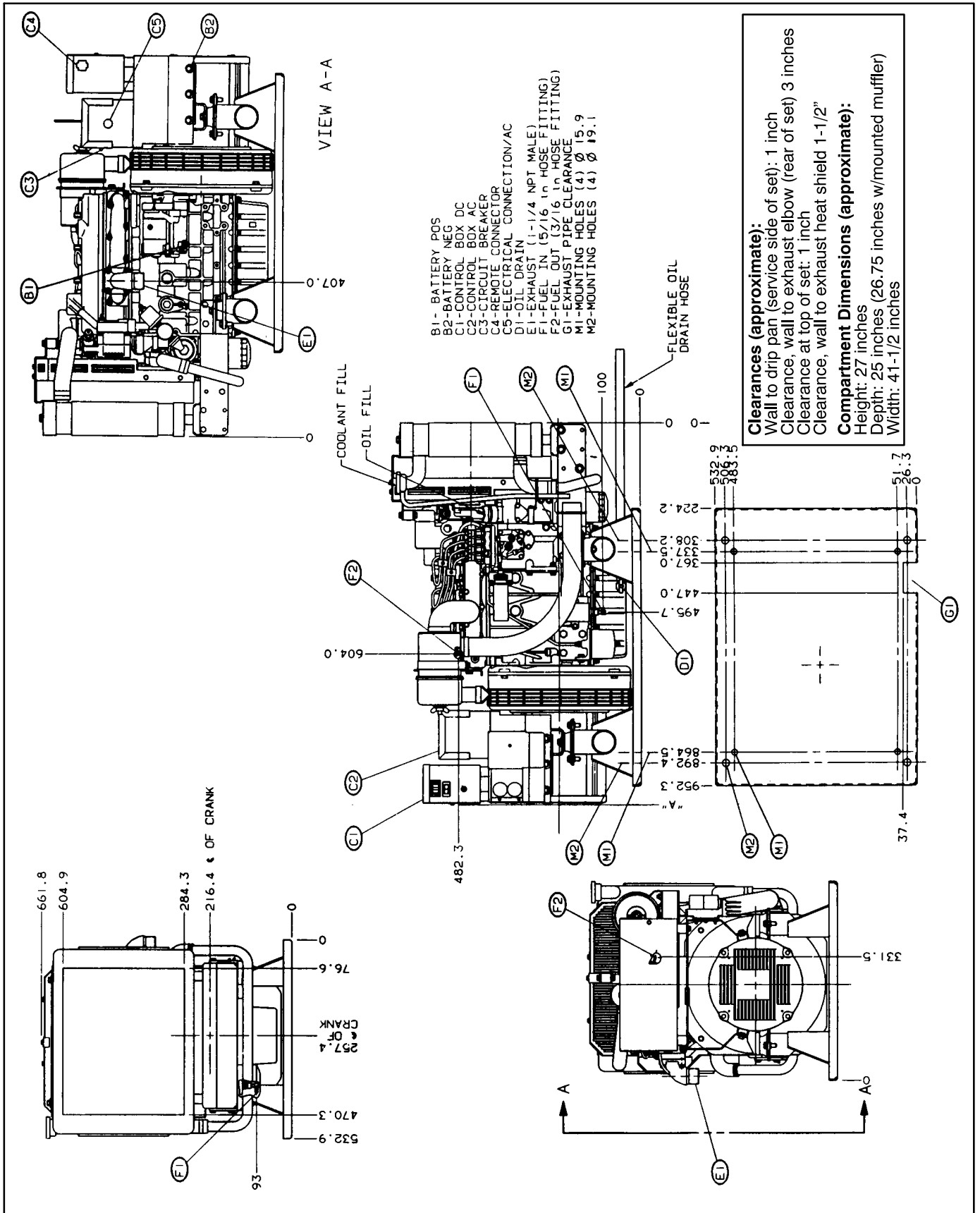
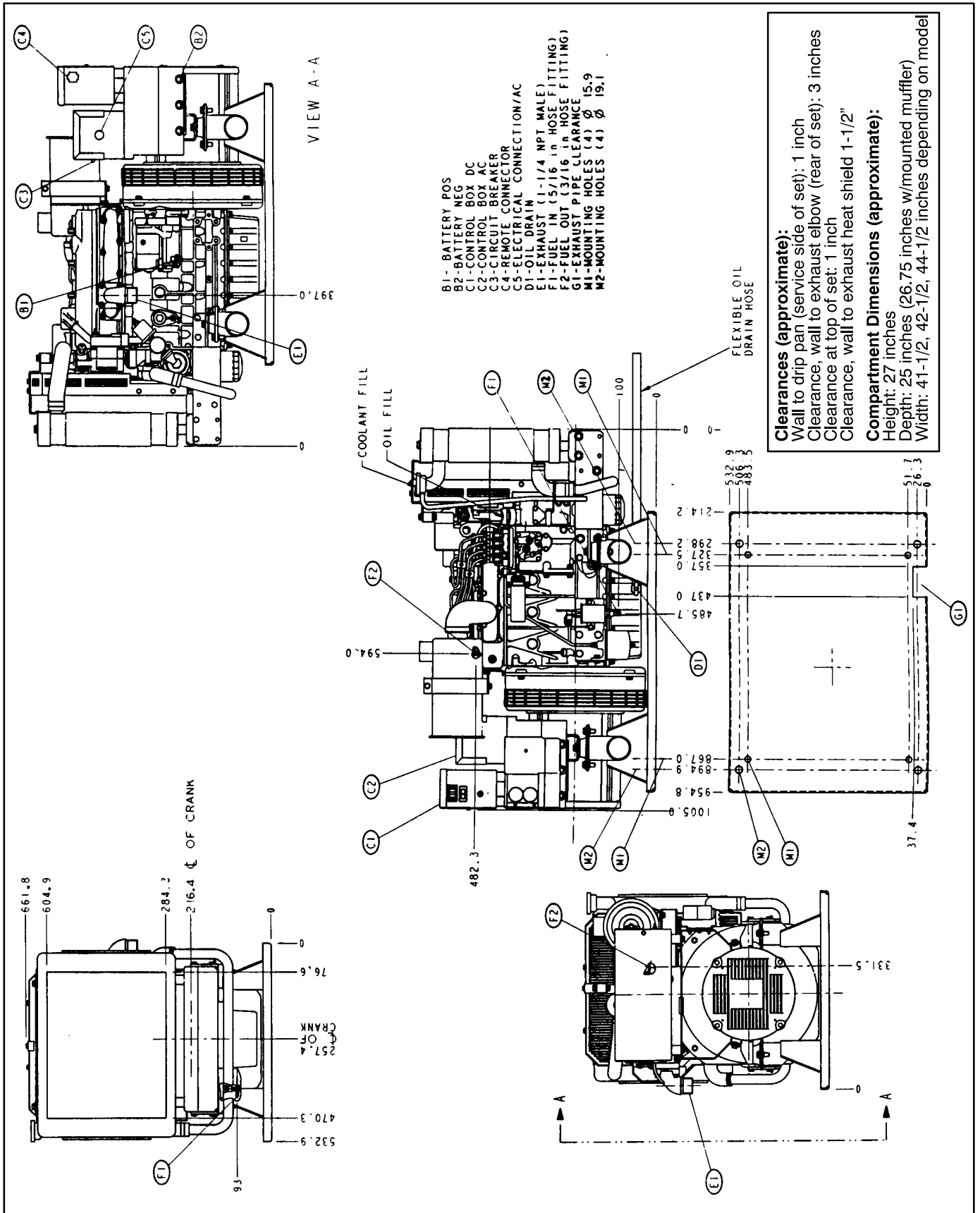

FIGURE 4-2. HDKAG DRIP PAN DIMENSIONS (THREE-PHASE)
(from 403-3566)



**FIGURE 4-3. HDKAG MOUNTING DIMENSIONS (SINGLE-PHASE generator set)
(from 500-2844)**



**FIGURE 4-4. HDKAG MOUNTING DIMENSIONS (STANDARD THREE-PHASE generator set)
 (from 500-2853)**

Slide-Mounting the Generator Set

An alternative mounting scheme, more suitable for commercial applications, is to mount the generator set in a “drawer” configuration, so that it may be slid in and out of the vehicle. Figure 4-5 illustrates such an installation. The generator set drip pan is bolted to two sliding drawer channels, which support its weight. The set is locked into position inside the vehicle when it is operated. When service is necessary, the set slides out of the vehicle, for easy access to both sides.

Note that the set compartment is open at both ends. This will improve ventilation, while increasing generator set noise. But on a commercial vehicle, noise reduction may be much less critical than on an RV installation, and minimal noise insulation may be acceptable.

Note that the exhaust system must be adequately supported along the full length of the exhaust tube, and especially toward the end. A flexible support is best for this mobile application. A shield is attached to the compartment door to protect the operator and others from contact with hot exhaust parts. The generator set exhaust configuration is described in Section 6 of this manual. Control box mounting is described in Section 9 of this manual.

⚠WARNING *Hot exhaust parts can cause severe burns. Make certain that the muffler and exhaust are adequately shielded from contact.*

More information on alternative mounting schemes may be obtained from Cummins. However, Cummins does not provide slide-mounting hardware for the HDKAG generator set.

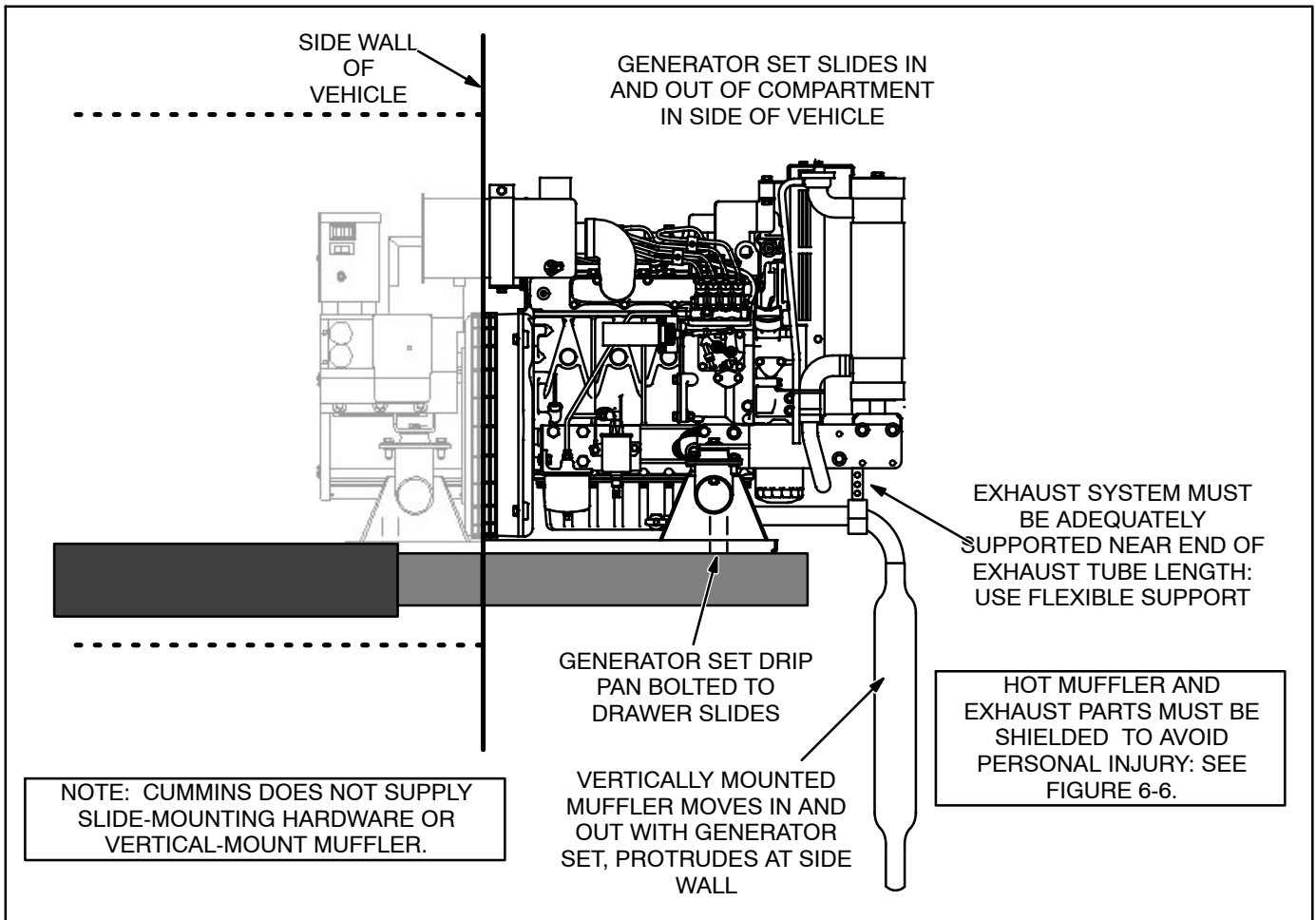
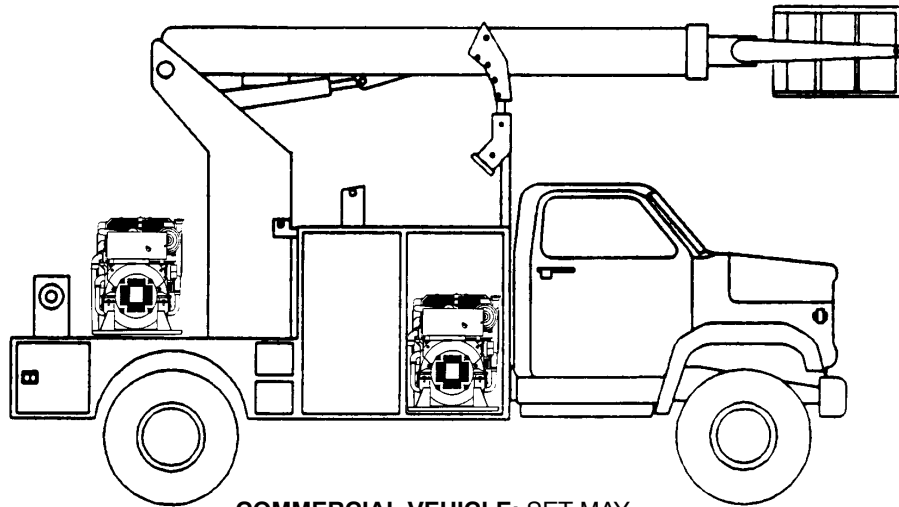
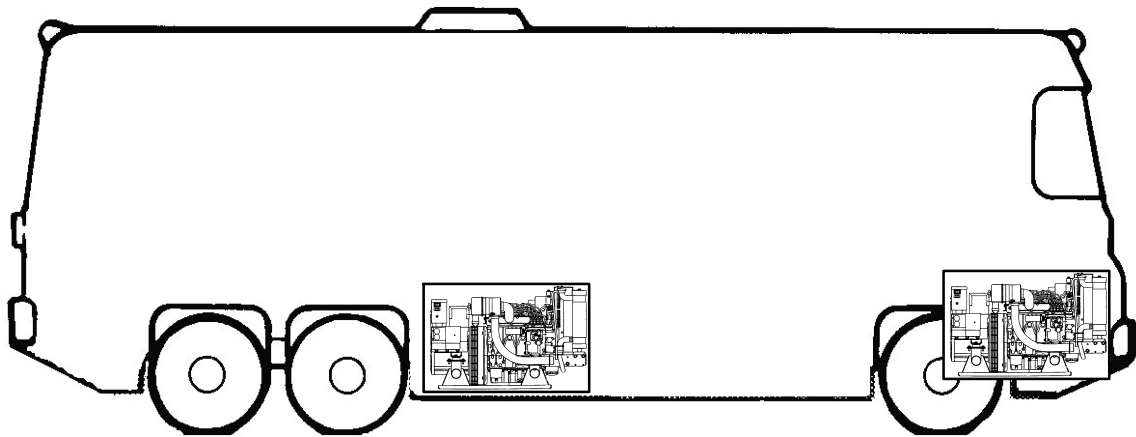

FIGURE 4-5. HDKAG IN SLIDE-MOUNTED CONFIGURATION (COMMERCIAL APPLICATION)



COMMERCIAL VEHICLE: SET MAY BE MOUNTED ON TRUCK BED OR IN COMPARTMENT WITH MINIMAL SOUNDPROOFING



RECREATIONAL VEHICLE: SET SHOULD BE MOUNTED IN SOUNDPROOF COMPARTMENT IN SIDE OF RV. ALTERNATIVE MOUNTING: SLIDE-OUT INSTALLATION IN NOSE OF RV.

FIGURE 4-6. SUGGESTED MOUNTING LOCATIONS IN COMMERCIAL AND RECREATIONAL VEHICLES

5. Ventilation and Acoustics

The most important factors of ventilation for radiator-cooled mobile generator sets are:

- Sufficient incoming cooling air
- Adequate exhausting of heated air

The HDKAG is normally supplied with a pusher-type fan. The pusher fan is normally used with sets that are mounted in the central area of the vehicle, at the perimeter of the chassis.

(A suction fan is available for certain installations. The suction fan is normally used with center-mounted generator sets, mounted in the front of large bus-type vehicles.)

⚠WARNING *Never use discharged cooling air for heating since it may contain poisonous gases. Inhalation of exhaust gases can result in severe personal injury or death.*

generator set cooling air requirements vary with type and size. Since the discharge area cannot be changed, the air inlet and outlet openings are critical. Be sure nothing obstructs or restricts discharged airflow.

The HDKAG generator set with a pusher fan is recommended for all compartment installations and requires an air inlet area of 375 in² (2420 cm²) and an

air outlet area (radiator end) of 193.75 in² (15.5 w x 12.5 h).

The HDKAG generator set with a suction fan is not recommended for installation in a restricted or closed compartment. These sets are designed for front vehicle mounting or other locations where free air movement is not restricted. Contact the Cummins distributor or factory for help on special installation considerations.

Use a foam gasket around the radiator opening on the inside of the compartment. An expanded metal grille can be used over the inlet and outlet. However, some provide only 60 percent free inlet area per square foot. Even the most efficient grille only provides about 90 percent free inlet area per square foot. The free inlet area of the material can be obtained from the grille manufacturer.

⚠WARNING *Leakage of fuel in or around the compartment can cause an explosion or fire resulting in severe personal injury or death. The ventilation system must provide a constant flow of air to expel an accumulation of fuel vapor. Compartments must be vapor-tight to the vehicle interior to keep fumes from entering.*

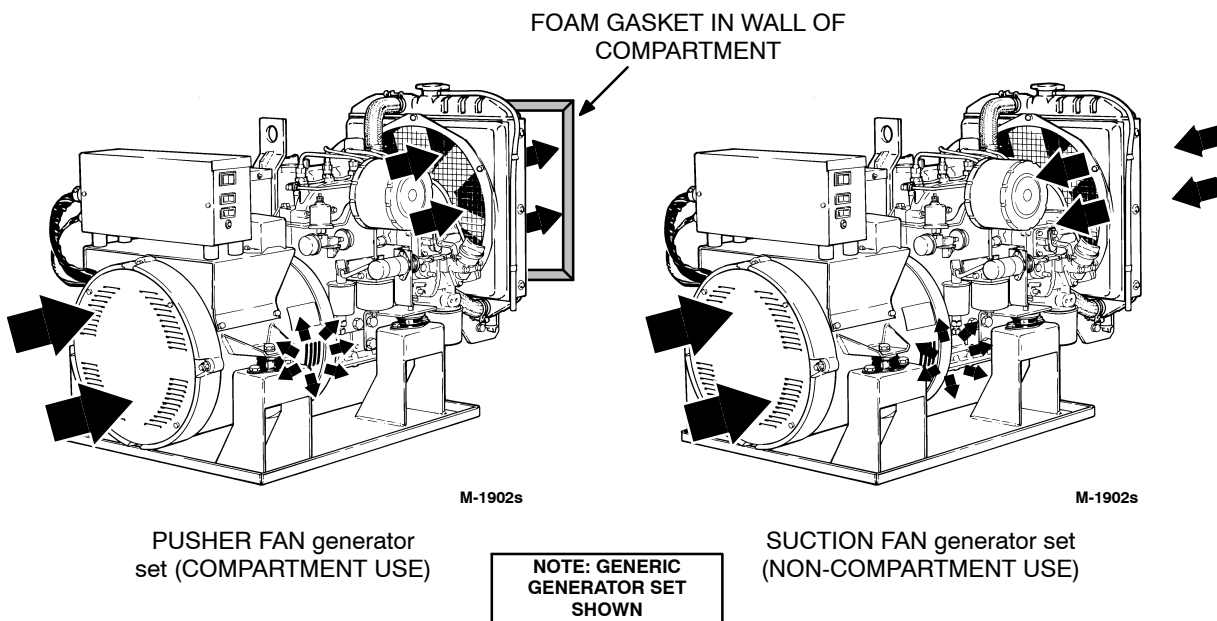

FIGURE 5-1. GENERATOR AND ENGINE COOLING AIRFLOW

THIS PAGE IS INTENDED TO BE BLANK

6. Exhaust System

GENERAL

Plan the exhaust system carefully. A vapor-tight, well-executed installation allows the generator set to be operated quietly and safely. The exhaust system installation must comply with all applicable standards, local codes and regulations. Study the following recommendations.

MUFFLER RECOMMENDATIONS

If the RV generator set was supplied without a muffler, we recommend the purchase of a Cummins RV spark arresting muffler that is constructed to meet RVIA and USDA standards for your RV generator set.

The RVIA/ANSI EGS-1 standard requires that the muffler must be constructed of aluminized steel or other corrosion resistant material, and it must be of a welded or crimped construction.

A USDA approved spark arrester that is designed for use with the muffler must be installed. The spark arrester may be an integral part of the muffler or it may be an add-on type. Failure to use and maintain a spark arresting exhaust system is illegal on federally-owned lands, and could cause brush or forest fires.

The Cummins spark arrester muffler is U.S. Forest Service-approved, and meets code requirements. Failure to provide and maintain a spark arrester can be a violation of applicable standards, codes and regulations.

Liability for damage or injury, and warranty expenses due to use of unapproved mufflers or installation modifications becomes the responsibility of the person installing the substitute muffler or performing the modifications. Contact a Cummins distributor or dealer for approved exhaust system parts.

EXHAUST INSTALLATION GUIDELINES

The exhaust system must be located no closer than 3 inches (76 mm) from combustible material (wood, felt, cotton, organic fibers, etc.), or be so located, in-

sulated or shielded that it does not raise the temperature of any combustible material more than 117° F (65° C) above the ambient air inlet temperature.

The exhaust system must extend a minimum 1 inch (25 mm) beyond the perimeter of the vehicle. Do not terminate the exhaust tailpipe under the vehicle. Be aware that any vent, window, storage compartment or opening that can be opened and that is not permanently sealed from the vehicle living space or work space can be an avenue for carbon monoxide to enter the vehicle. The tailpipe must not terminate so that any vent, window, or opening into the living area (RV) or the work area (commercial vehicle) is within the triangular area shown in Figure 6-1. This area is defined as an isosceles triangle with a height of 3 feet measured from the center of the tailpipe termination and with a base of 2 feet measured one foot horizontally from the center of the pipe in either direction.

⚠WARNING *Exhaust gas is deadly and presents the hazard of severe personal injury or death. Do not terminate an exhaust pipe under the vehicle. The tailpipe must not terminate so that any vent, window, or opening into the living area is within the triangular area shown in Figure 6-1. Keep all openings closed when the generator set is running.*

To reduce the chance of damaging the tailpipe and emitting exhaust gases under the vehicle, make certain that no part of the exhaust system intrudes into the departure angle or approach angle of the vehicle, unless it is protected by a skid bar or other protection device. The shaded areas in Figure 6-1 illustrate typical mounting locations.

⚠WARNING *Exhaust gas presents the hazard of severe personal injury or death. Do not mount any portion of the exhaust system into the approach or departure angle unless it is adequately protected. Use only Cummins specified exhaust equipment with the generator set. Use a sufficient number of hangers to prevent dislocation of the system.*

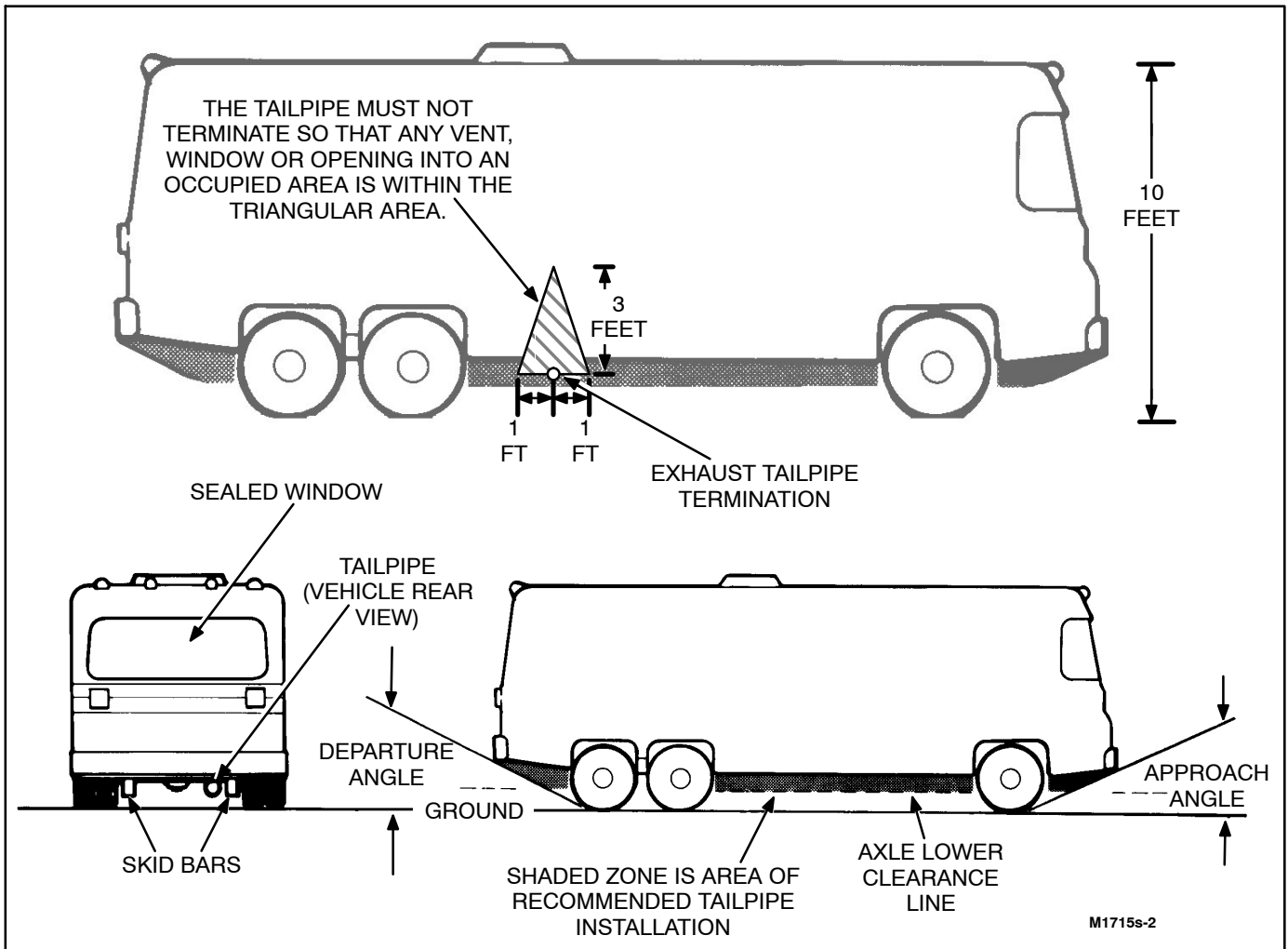

FIGURE 6-1. TAILPIPE INSTALLATION

TAILPIPE RECOMMENDATIONS

An exhaust tailpipe is not supplied with the generator set because length requirements vary between vehicle manufacturers. Refer to the following recommendations for information and safety considerations.

Use 1-1/2 inch (38.1 mm) I.D. 18 gauge rigid steel tubing for tailpipe. This size is sufficient for 20 foot (6 m) lengths. Greater lengths may require a larger pipe size to prevent excessive back pressure.

The maximum allowable back pressure measured at the exhaust manifolds is 2.57 inches (65 mm) mercury (8.7 kPa). Back pressure readings higher than this might adversely affect engine performance.

⚠WARNING *Exhaust gas presents the hazard of severe personal injury or death. Do not use flexible exhaust tailpipe, because it can leak or break from road shock or vibration. Do not terminate the exhaust system under the vehicle. Direct exhaust gases away from any window, door, or compartment openings. Do not operate the generator set without an exhaust tailpipe.*

Use a U-bolt type automotive muffler clamp to connect exhaust tailpipe to muffler outlet.

If the tailpipe extends beyond 1-1/2 foot (0.46 m) from the generator set, attach an automotive tailpipe hanger for additional support. Also use additional automotive type tailpipe hangers every 2 to 3 feet (0.6 to 0.9 m) of tailpipe run. See Figure 6-2.

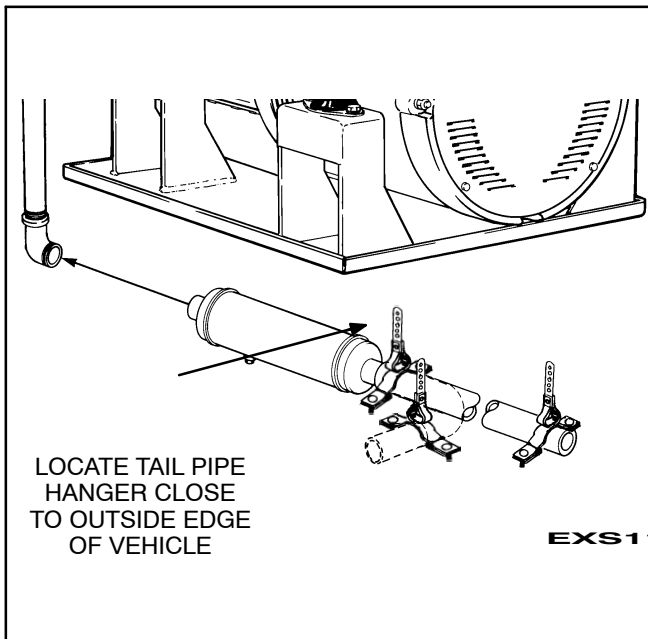

FIGURE 6-2. EXHAUST PIPE SUPPORT

Support the exhaust system at or near the perimeter of the vehicle to prevent the pipe from being damaged and pushed up under the vehicle skirt. Attach hangers to steel framework, not wood or other floor materials. Protect the tailpipe by locating it in the shaded area in Figure 6-3. Extend the pipe at least one inch outside the vehicle as shown in Figure 6-4.

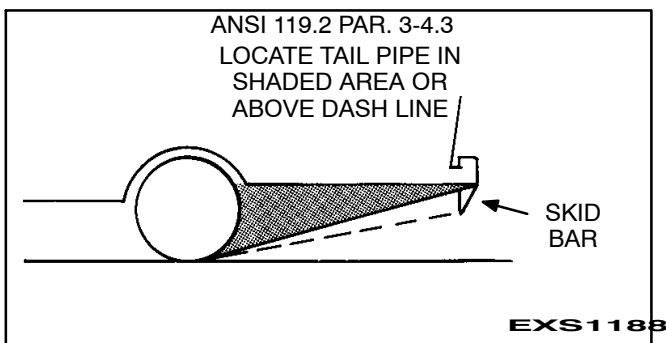

FIGURE 6-3. TAIL PIPE PROTECTION

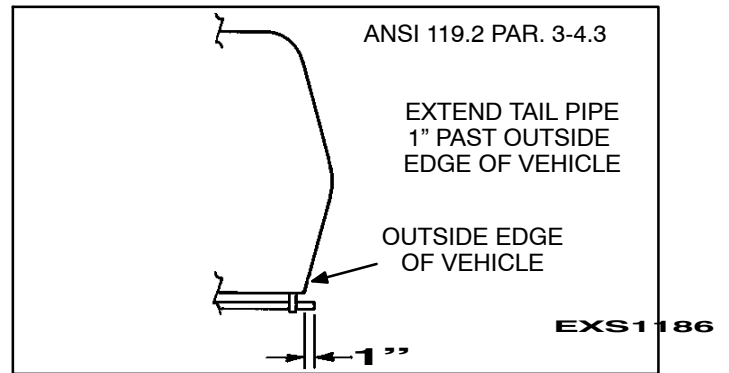

FIGURE 6-4. TAIL PIPE EXTENSION BEYOND VEHICLE

CAUTION Excessive exhaust back pressure can cause engine damage. If a tailpipe deflector is used, make sure it is large enough to prevent back pressure.

CAUTION Water vapor can cause engine damage. Do not connect the generator set exhaust to the vehicle exhaust system, because water vapor from one engine can damage the other.

The following procedure refers to the exhaust installation drawing in Figure 6-2.

1. The downpipe plumbing from the engine exhaust manifold should be completed before the unit is set in place and secured.
2. Install elbow on downpipe, then turn muffler onto the elbow. The muffler cleanout plug must face downward.
3. Attach tailpipe to muffler with a U-bolt type exhaust system clamp and hanger. Use an automotive tailpipe hanger for additional support at the perimeter of the vehicle.

CAUTION Angular mounting of muffler and tailpipe hanger brackets can result in exhaust system damage. Properly mounted hanger brackets will absorb much road shock vibration and prolong the use of exhaust system components. Mount muffler and tailpipe hanger brackets directly above the component supported, not at an angle. Do not twist the rubber sections of any hangers.

ALTERNATE EXHAUST INSTALLATIONS

Figure 6-5 illustrates an HDKAG generator set that is installed to slide in and out of a commercial vehicle. In this application, the exhaust pipe, muffler

and tailpipe slide in and out of the vehicle along with the generator set. A metal screen protects the hot exhaust system from being touched by the operator or others. The exhaust screen is attached to the access door to the generator set, and swings away when it is opened. More information on this and other mounting schemes may be obtained by contacting Cummins.

⚠WARNING *Contact with hot muffler and exhaust system parts can cause severe burns. If installing the generator set in a sliding-drawer configuration, make certain that shields or screens are fabricated that will effectively protect the user from contact with the muffler or tailpipe.*

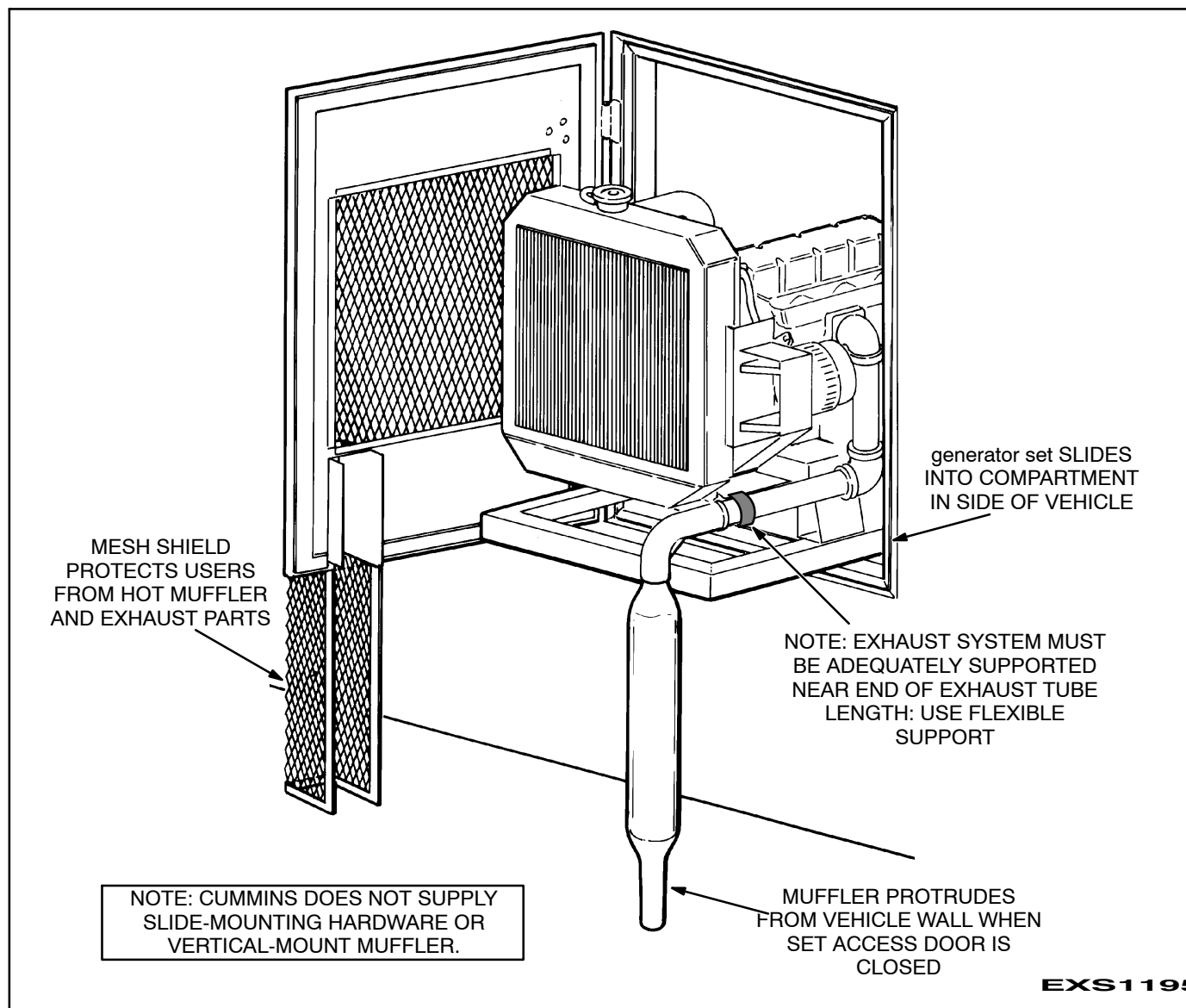

FIGURE 6-5. EXHAUST ROUTING FOR SLIDE-MOUNT GENERATOR SET (COMMERCIAL APPLICATIONS)
(see Figure 4-5)

7. Cooling System

COOLANT RECOVERY TANK

A coolant recovery tank should be installed with each generator set. Figure 7-1 shows a typical installation.

Use the bracket as a template to locate mounting holes. Allow a minimum of 2 inches (51 mm) from the top of the tank to any upper structure so the tank can be lifted off the bracket for servicing. Mount with two 5/16 inch (8 mm) bolts.

Use a length of hose from the kit between the radiator overflow and the dip-tube connector on the recovery tank. This hose is heavier and resists collapse from vacuum. The original hose may be used on the overflow side to the drain. Allow sufficient hose lengths so the tank can be easily removed from the bracket to add coolant.

Engine coolant is at proper level when the recovery tank level is between Full and Low (engine cold).

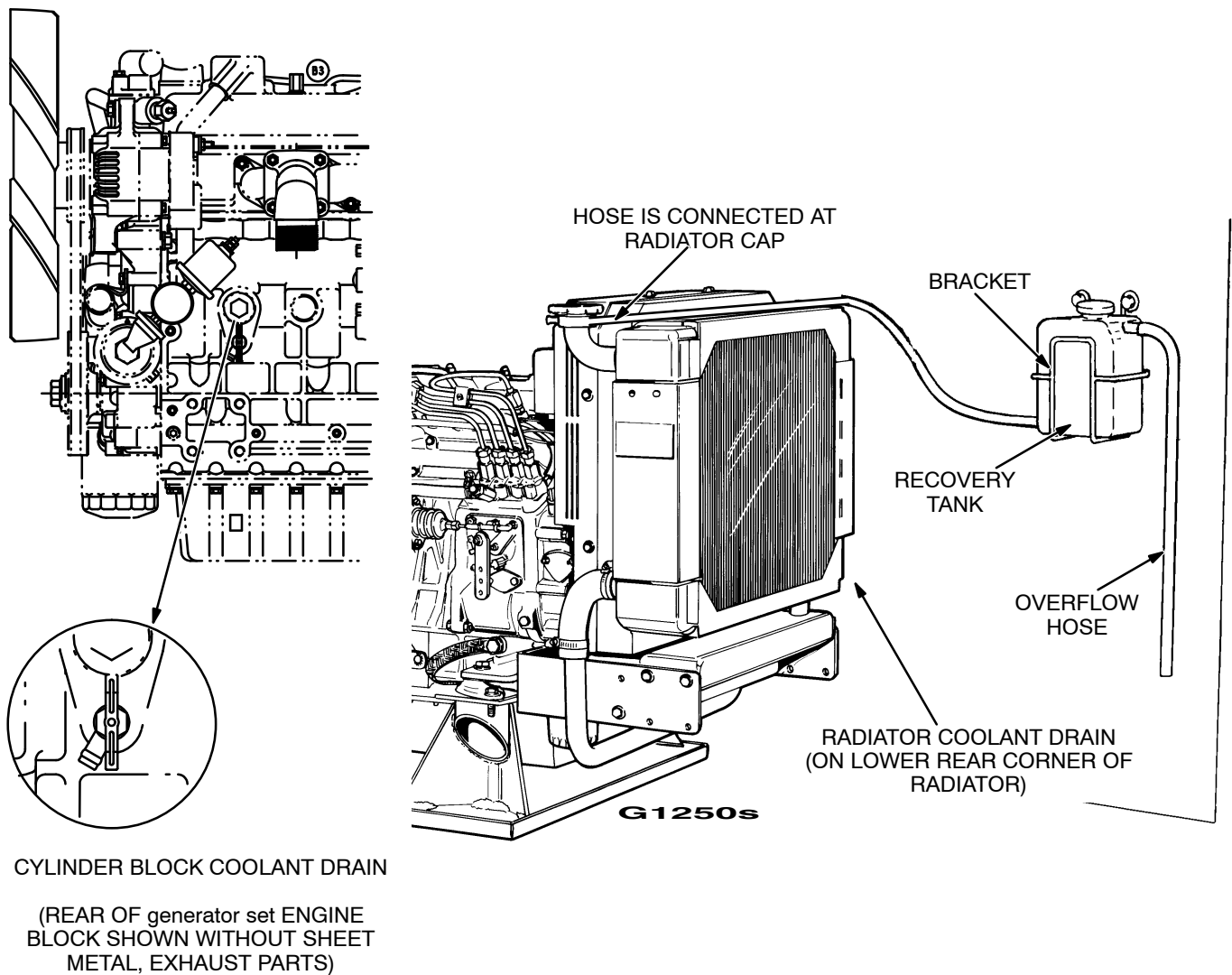

FIGURE 7-1. COOLING SYSTEM COMPONENTS

THIS PAGE IS INTENDED TO BE BLANK

8. Fuel System

GENERAL

This section describes fuel system installations for commercial and recreational vehicles.

⚠WARNING *Fuel presents the hazard of fire or explosion that can result in severe personal injury or death. Do not smoke or allow any flame, spark, pilot light, arc-producing equipment or other ignition sources around fuel or fuel components, or in the installation area. Keep a type ABC fire extinguisher nearby. The ventilation system must provide a constant flow of air to expel any accumulation of fuel vapor while the vehicle is in transit. Compartments must be vapor-tight to the vehicle interior to prevent any fumes from entering these areas.*

FUEL SYSTEM

Fuel System Provisions

On some vehicles, the generator set can share the vehicle fuel supply tank with the vehicle engine. Connection to the vehicle fuel tank must be made according to the chassis (vehicle) manufacturer's detailed instructions. See *Fuel Line Installation*, in this section.

Cummins recommends a separate fuel pickup tube or a separate fuel tank. Connection with the vehicle fuel line is not recommended; this may restrict flow to the generator set.

Cummins recommends installing an in-line manual fuel shutoff valve, to close the fuel line when the set is removed for service.

Recommended Fuel

Use ASTM 2-D (no. 2 Diesel) or ASTM 1-D (No. 1 Diesel) fuel with a minimum Cetane number of 45. Number 2 diesel fuel gives the best economy and performance under most conditions. Use number 1 diesel fuel when ambient temperatures are below 32° F (0° C), and during long periods of light engine load.

Use low sulfur content fuel which has a cloud point at least 10 degrees below the lowest expected fuel temperature. (Cloud point is the temperature at which wax crystals begin to form in diesel fuel.)

⚠WARNING *Fuel presents the hazard of fire or explosion that can cause severe personal injury or death. Never fill the fuel tank when the engine is hot or is running. Do not permit any flame, spark, pilot light, cigarette or other ignition source near the fuel system.*

Fuel Consumption

Generator set fuel consumption varies proportionately to differing electrical loads. Refer to the *Specifications* section for approximate fuel consumption at no load, half load, and full load.

Fuel Line Installation

Vehicle fuel systems operate at a specified fuel pressure. For this reason, do not change or remove the fuel fill tube, fill limiter vent, vapor canister, vapor lines, filler cap and all parts of the fuel system without the approval of the vehicle manufacturer. Check the filler cap to make sure that the pressure vacuum relief valve functions properly: replace it if necessary.

If a separate connection is not supplied for the generator, add a second fuel pickup in the tank. This pickup should not extend below the bottom 1/4 of the tank, so the vehicle will run after the generator runs out of fuel.

Do not tee off the vehicle fuel pickup line. This may cause the generator set or the vehicle engine to run poorly. Consult the vehicle manufacturer for information on shared fuel supplies. Unauthorized fuel system modifications can cause dangerous operating conditions.

⚠CAUTION *Never use galvanized or copper fuel lines, fittings or fuel tanks with diesel fuel systems. Condensation in the tank and lines combines with the sulfur in diesel fuel to produce sulfuric acid. The molecular structure of the copper or galvanized lines or tanks reacts with the acid and contaminates the fuel.*

⚠CAUTION *The generator set could starve for fuel when the vehicle is operated at highway speeds if its fuel line is connected to the main fuel line with a tee. The generator set fuel pump has neither the capacity nor the power to overcome the draw of the vehicle engine fuel pump. For this reason, use a separate fuel line to the generator set, or use a separate fuel tank.*

Install an approved flexible non-metallic and non-organic fuel line between the vehicle fuel system and the generator set to absorb vibration. Flexible line must be long enough to prevent binding, stretching or breaking during set movement. Connect the fuel line to the generator set fuel pump using a 5/16 inch connector.

Cummins recommends seamless steel tubing and flared connections for long runs between the fuel tank and the flexible connector to the generator set.

Run fuel lines at the same height as the top level of the tank, to a point as close to the engine as possible. This reduces the danger of fuel siphoning out of the tank if the line should break.

Keep fuel lines away from hot engine or exhaust areas, to reduce the chance of vapor lock. Fuel lines should be accessible and protected from damage. Use metal straps without sharp edges to secure fuel lines. Do not run fuel lines where they may contact sharp or rough surfaces, or where they may be kinked, pinched, chafed, or struck.

⚠WARNING Diesel fuel can be accidentally ignited by electrical sparks, presenting the hazard of fire or explosion, which can result in severe personal injury or death. For this reason, when installing the generator set:

- **Do not tie electrical wiring to fuel lines.**
- **Do not run electrical lines and fuel lines through the same compartment openings.**
- **Keep electrical and fuel lines as far apart as possible.**
- **Place a physical barrier between fuel lines and electrical lines wherever possible.**
- **If electrical and fuel lines must pass through the same compartment opening, make certain that they are physically separated by running them through individual channels, or by passing each line through a separate piece of tubing.**

BIO-DIESEL FUELS B5 – B20

Approved Bio-Diesel Fuel:

For biodiesel blends above B5 and up to B20, Cummins requires that the fuel meet the specifications outlined in ASTM D7467. The bio-diesel

component of this fuel blend must meet ASTM D6751 or EN14214 and the petroleum-diesel component must meet ASTM D975.

For bio-diesel blends above B5 and up to B20 the following installation requirements must be met:

- Natural rubber, butyl rubber, and some types of nitrile rubber may be particularly susceptible to degradation when exposed to bio-diesel. Also, copper, bronze, brass, tin, lead, and zinc can cause deposit formations. The use of these materials and coatings should be avoided for vehicle fuel tanks and fuel lines. Always check with component manufacturers to confirm compatibility with B20.
- Fuel tanks must be made from the following materials: aluminum, steel, fluorinated polyethylene, fluorinated polypropylene or Teflon (PTFE).
- Verify the vehicle propulsion engine is capable of using B20 when sharing the same fuel tank with the generator set.
- A bio-diesel compatible fuel water separator is required. Because water separators do not work as well with bio-diesel as they do with petroleum-based diesel, it is very important to prevent water from entering the fuel supply.

Place the fuel water separator in a location that is accessible for service by as close the generator set as possible. Locating the separator ahead of the generator set fuel pump is acceptable.

Additional information:

- Bio-diesel blends have higher pour and cloud points than standard diesel fuels. Generator set locations far from the fuel tank combined with low fuel flow rates can make the generator set fuel system very susceptible to fuel starvation related to gelling in cold weather (below 23°F/ -5°C). In addition to electric or coolant tank heaters, consideration to routing and possible heating or insulation of the fuel lines to the generator set may be needed.
- Bio-Diesel blends can oxidize more quickly than standard diesel fuels; more frequent fuel filter service intervals are required and shorter fuel storage life in tanks is likely.

▲WARNING It is highly recommended that specific market applications are avoided or exercised with extra care due to some of the properties of bio-diesel fuel blends such as cold weather operation, long term storage, material incompatibilities and other effects on engine operating characteristics. Such applications that should use standard fuels include applications that will experience seasonal usage, storage for periods exceeding 90 days, and extreme temperatures or humidity.

Storage requirements:

- If using bio-diesel for seasonal applications (stored more than 90 days), the generator set must be purged before storage by running the engine on pure diesel fuel meeting ASTM D975 for a minimum of 30 minutes.

TABLE 1-1. CUMMINS BIO-DIESEL RECOMMENDATIONS

APPLICATION	RECOMMENDATION FOR BIO-DIESEL BLENDS	RECOMMENDATIONS	COMMENTS
Emergency Standby RV Seasonal/Commercial with low annual hour accumulation	Not Recommended	Use petroleum diesel only.	Low fuel usage and critical start nature of Emergency Standby make bio-diesel impractical.
Limited Time Prime	Approved with Recommendations	Use fuel within 6 months of manufacture. Flush fuel system with petroleum diesel prior to storage.	Bio-diesel is suitable for constant high load operation with proper precautions.
Unlimited Time Prime	Approved with Recommendations	Use fuel within 6 months of manufacture. Flush fuel system with petroleum diesel prior to storage/transport.	Bio-diesel is suitable for variable load operation with proper precautions.
Continuous	Approved with Recommendations	Use fuel within 6 months of manufacture.	Bio-diesel is suitable for base load operation with proper precautions.

THIS PAGE IS INTENDED TO BE BLANK

9. Electrical Connections

GENERAL

Installing the generator set electrical system includes connecting the load and connecting the battery. Always connect the battery last to avoid accidental starting of the unit during installation.

⚠️WARNING *Accidental starting of the generator set during installation can cause severe personal injury or death. Do not connect the starting battery until instructed to later in this section.*

⚠️CAUTION *Improper operation can result in overheating and equipment damage. On installations that use a common radiator for both vehicle engine and generator set cooling, the units must be wired to prevent operation of the vehicle engine and the generator set at the same time or equipment damage can result due to overheating.*

Wiring must be protected from sharp edges (screw heads, burrs, fins, moving parts), hot engine parts,

exhaust system, fuel system, or any other objects that might damage the insulation.

The wiring must meet all applicable electrical codes. Have a qualified electrician install and inspect the wiring. All remote controls and switches must be vibration-proof and securely mounted to prevent accidental closing or opening when the vehicle is moving.

CONDUIT

Route load conductors from the generator set control to the junction box in approved flexible conduit. See Figure 9-1. Make sufficient slack in conduit to allow the unit free movement and for maintenance.

Be sure all openings made through the compartment for conduit and wiring and into the coach interior are sealed and vapor-tight. Seal wiring within the conduit if conduit terminates in the coach.

⚠️WARNING *Inhalation of exhaust gases can cause severe personal injury or death. Seal all openings into the vehicle interior to prevent the entrance of exhaust gases.*

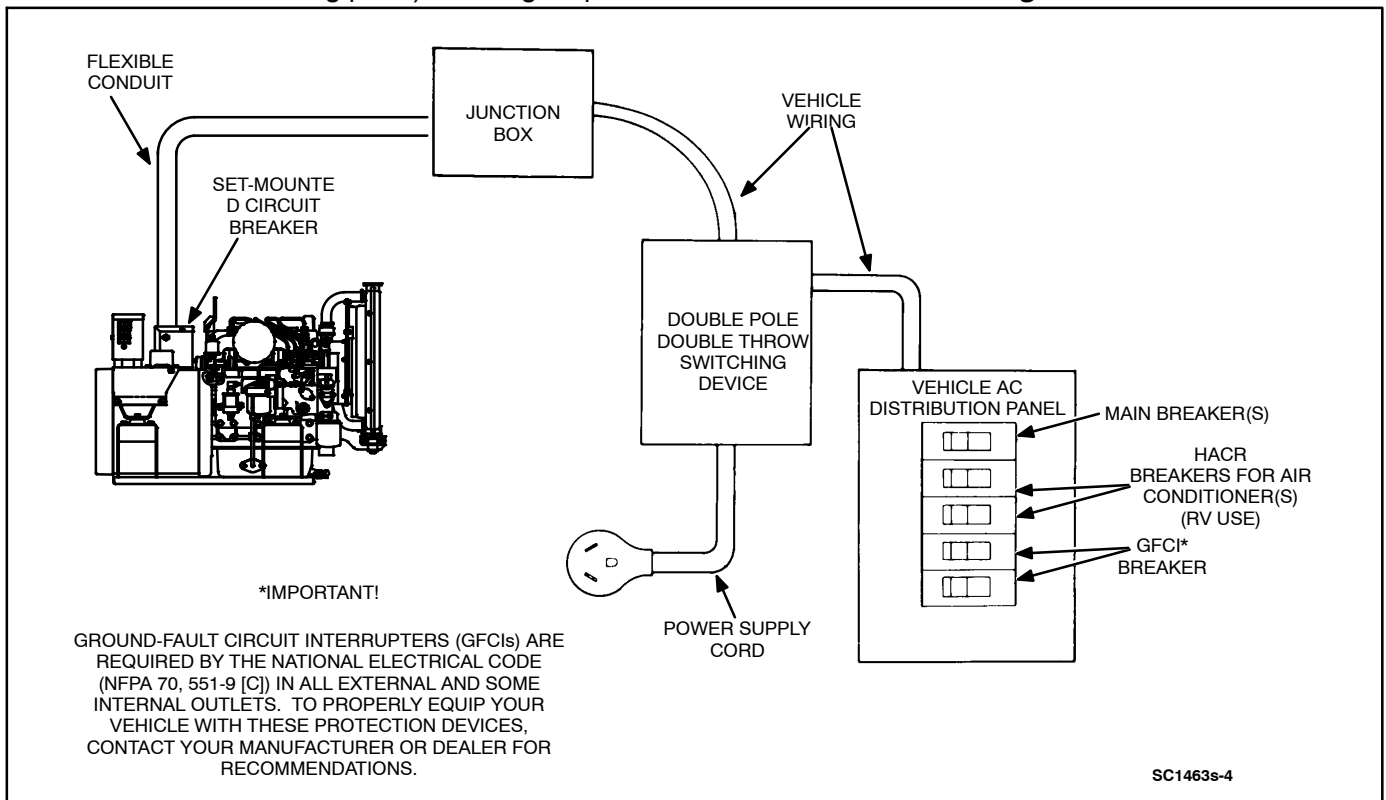

FIGURE 9-1. TYPICAL POWER SWITCHING DEVICE

WIRING DISCONNECT

The feeder conductors from the generator set compartment must terminate at a disconnecting device or a double-pole double-throw switching device if 120 VAC, or a 3-pole double throw device if 120/240 VAC, so that the outside power source conductors cannot be connected to the generator set.

Never remove the grounding pin from power supply assemblies. Incorrect or no ground can cause the vehicle to be electrically “hot” and result in shock or electrocution.

⚠WARNING *Contact with electrically “hot” equipment can result in severe personal injury or death. It is extremely important that bonding and equipment grounding be properly done. All metallic parts which could become energized under abnormal conditions must be properly grounded.*

LINE CIRCUIT BREAKERS

The single-phase 10.0 kW HDKAG generator set has one 45-ampere, 120-volt, two-pole circuit breaker mounted on the side of the control box. The three-phase HDKAG generator set has one three-pole 35-ampere circuit breaker. Circuit breakers for the 8.0 KW three-phase 50 Hz HDKAG generator set are sold separately as kits. The circuit breaker provides short circuit or other overload protection for the generator.

LOAD CONNECTIONS

The generator output voltage(s) and maximum current rating(s) are specified on the generator nameplate. Line-to-neutral voltage is always the lower voltage shown on the nameplate and line-to-line voltage is the higher rating. Refer to Figures 9-2,

9-3 and 9-4 for AC output and generator reconnection diagrams.

Connecting the Load

Install the generator output conductors in approved flexible conduit. Cut conduit to desired length, leaving a minimum of 8” extra wire in the junction box for making connections to the load. Route conduit so movement of set is not interfered with.

Load wiring must be appropriately sized and insulated for the specified current rating. Grounding procedure must comply with codes.

NOTE: For the supply connection, use wires suitable for at least 90° C.

A lead to be connected to an output feeder conductor shall be not more than two AWG sizes smaller than the output feeder conductor and the insulation shall be rated for at least 45 amps and be:

- Rubber (with a braid), neoprene, or thermoplastic, with a wall thickness of at least 0.030 inch (0.76 mm)
- Other material having the same or better electrical and mechanical properties.

⚠WARNING *Improper wiring can result in fire and severe personal injury or death. Do not allow contact between electrical wiring and the fuel line.*

⚠WARNING *Electrical shock can result in severe personal injury or death. Properly applied and maintained ground fault interrupters can afford additional protection against the hazard of electrical shock. Equip the vehicle with adequate ground fault protection devices to meet the National Electrical Code Code NFPA 70, 551-9 (c).*

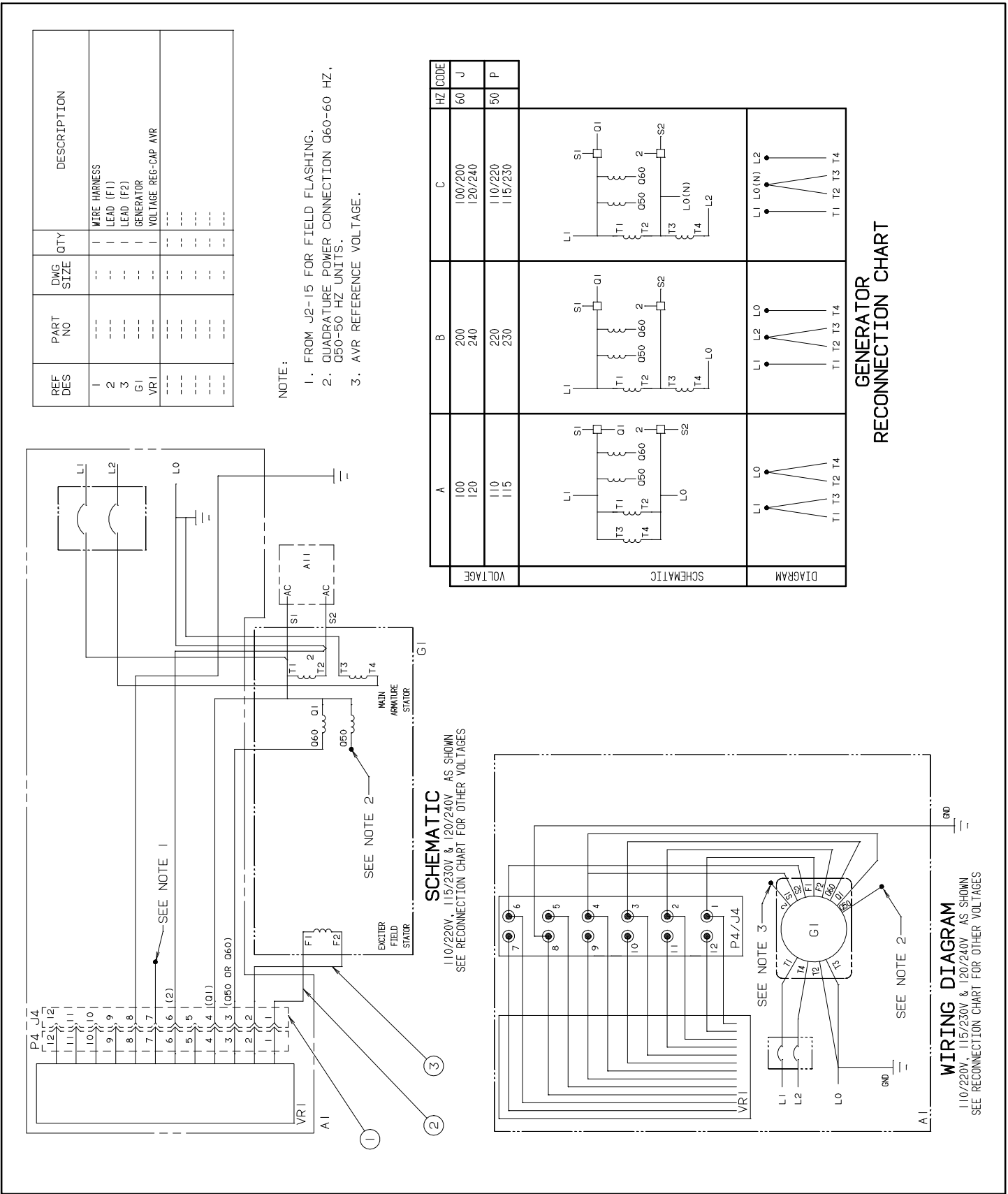

FIGURE 9-2. SINGLE-PHASE GENERATOR SCHEMATIC, WIRING DIAGRAM AND RECONNECTION CHART (from 612-6637)

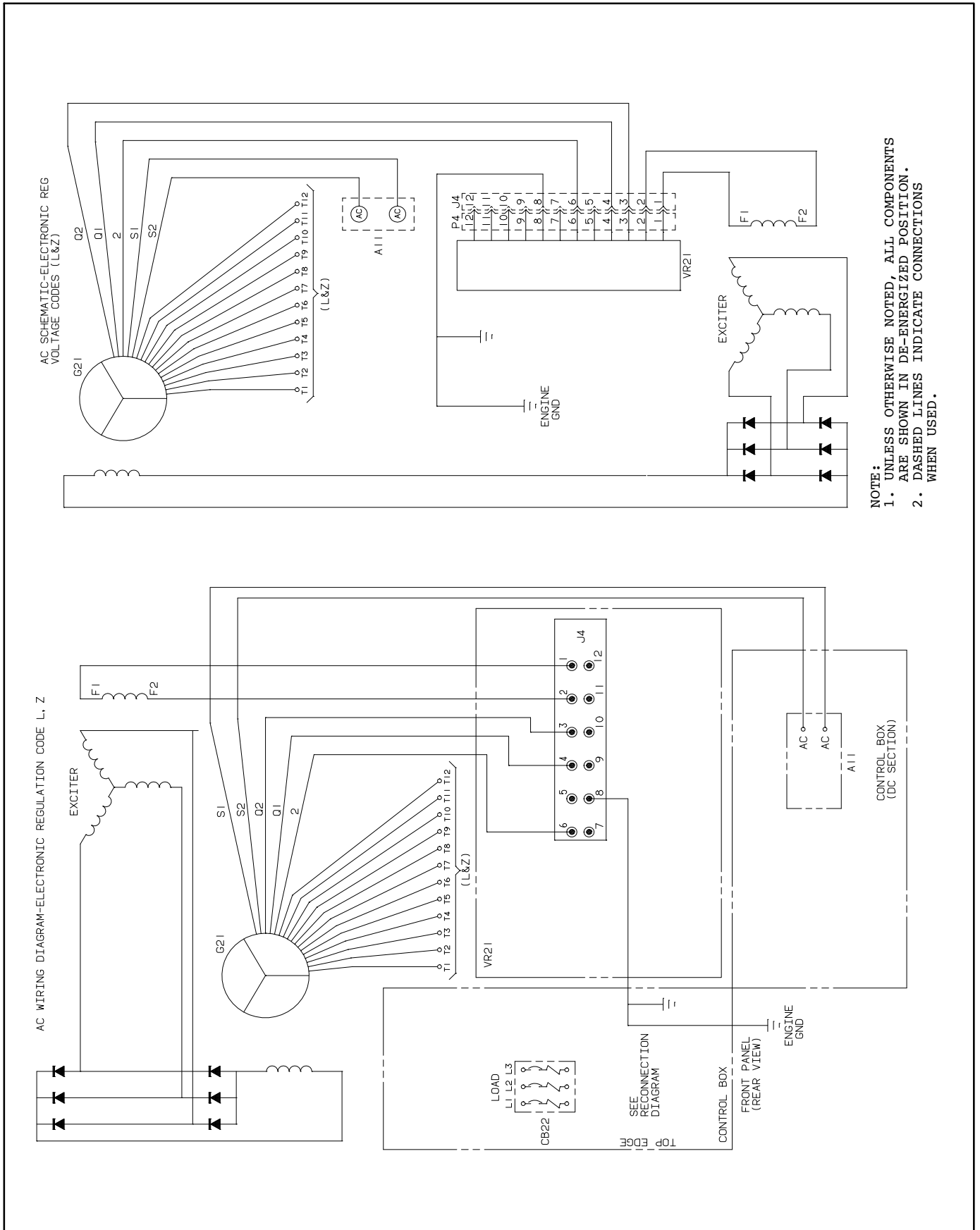
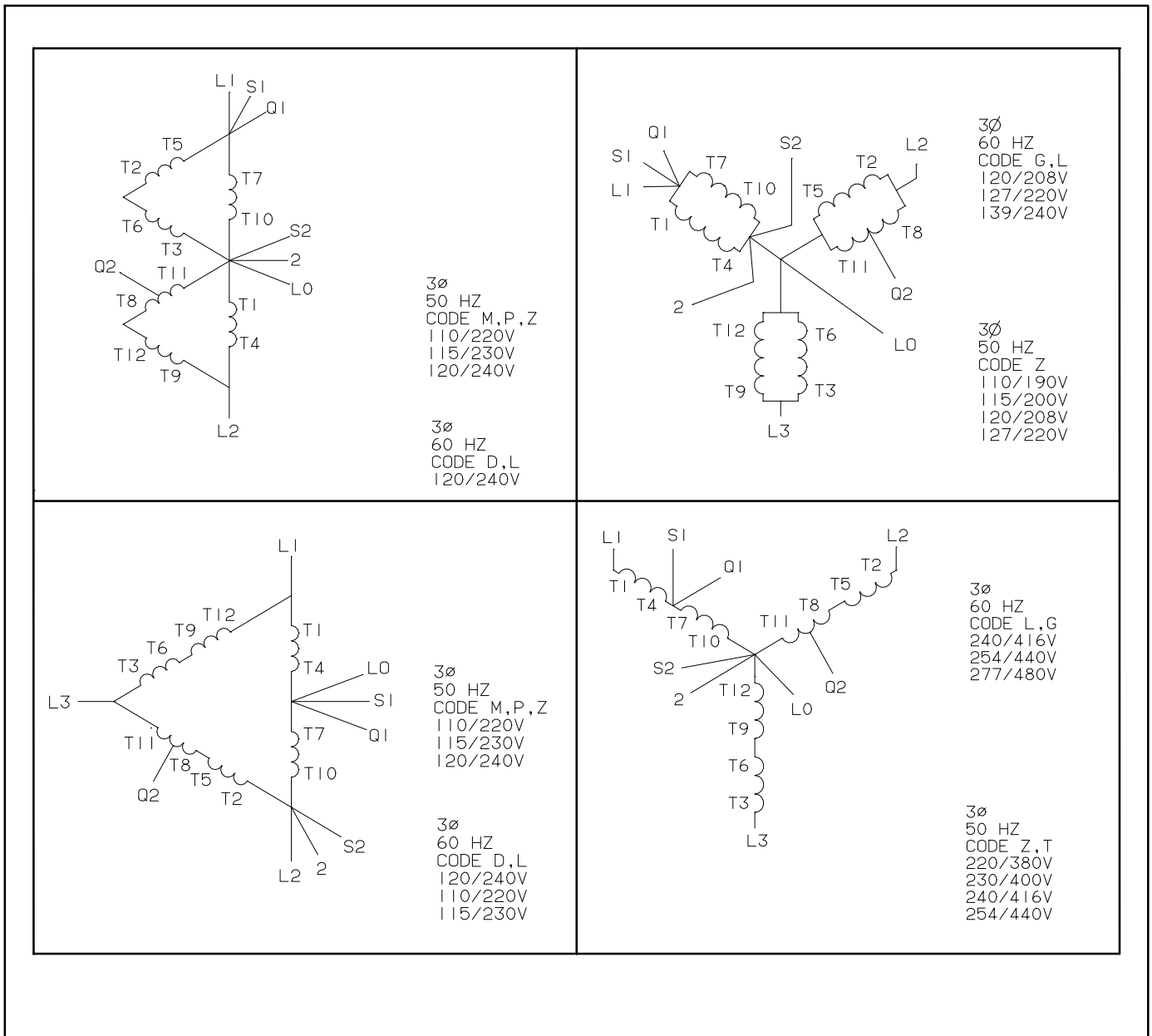

FIGURE 9-3. THREE-PHASE GENERATOR WIRING DIAGRAM AND SCHEMATIC (from 612-6652)



**FIGURE 9-4. THREE-PHASE GENERATOR RECONNECTION DIAGRAM
(from 612-6652)**

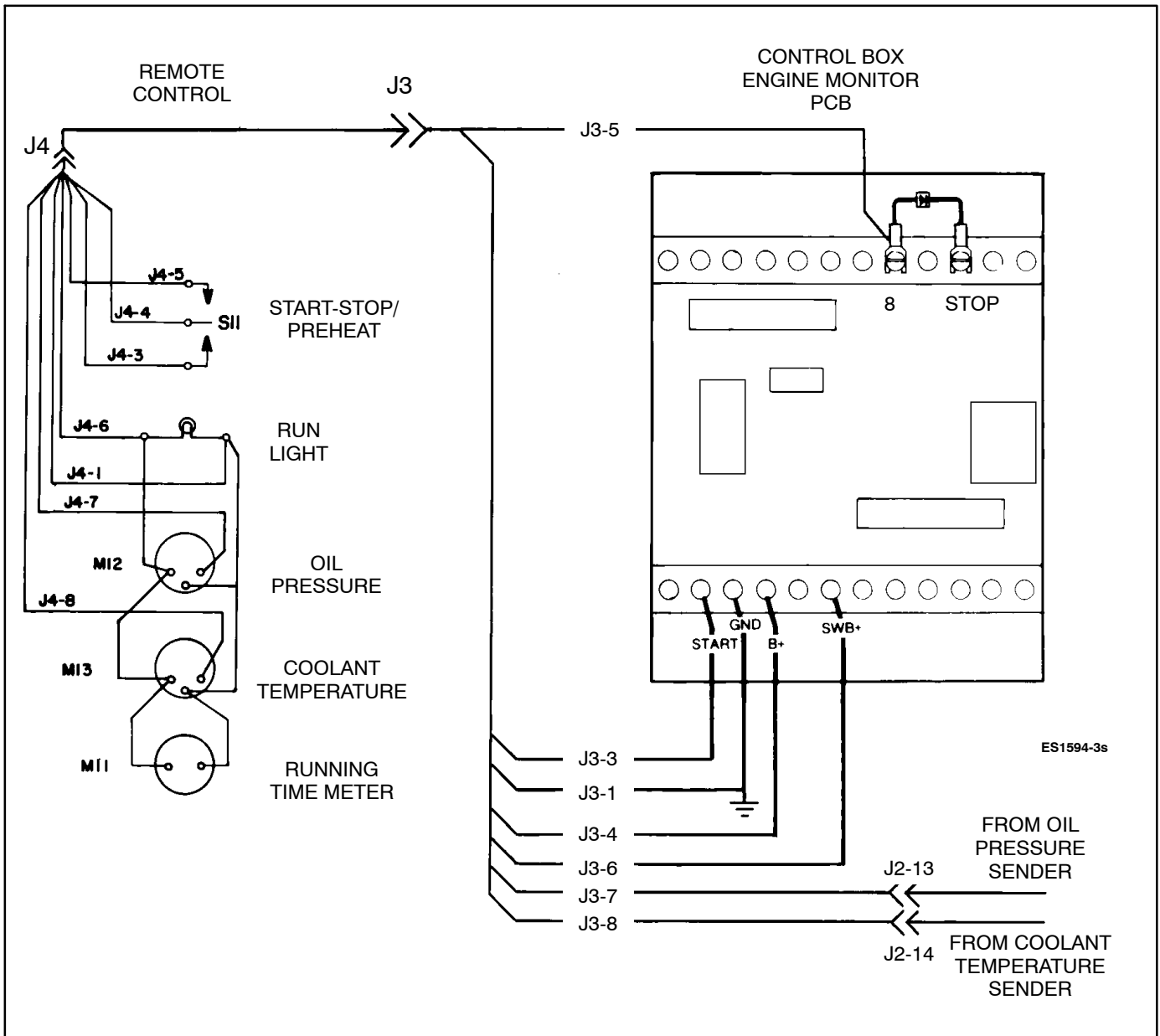

FIGURE 9-5. REMOTE CONTROL CONNECTIONS

REMOTE CONTROL CONNECTIONS

Provision is made for addition of remote starting and stopping of the generator set. A nine-pin remote connector (J3) mounted on the control box connects the harness assembly to connector J4 on the remote control assembly. A remote control kit complete with installation instructions is available. Also available are complete harness assemblies with connectors in 15 and 25 foot lengths (4.6 and

7.6 m). Call the Cummins dealer or distributor for assistance in securing these items.

The wiring diagram in Figure 9-5 is furnished so a harness can be fabricated if desired. Use 16 AWG wire. The electrical code does not allow the remote control harness/wiring to be routed through the same conduit as the AC load wiring. Follow all national electrical codes and any local codes that may apply.

Be sure to seal all openings made for wiring so exhaust or fuel vapors cannot enter the living quarters or work area. Conduit must be sealed internally at the end where it terminates within the junction box or panelboard.

⚠WARNING *Inhalation of exhaust gas or ignition of fuel vapor can cause severe personal injury or death. Be sure to vapor-seal flexible metal conduit and all openings made during installation of the generator set with a silicone/rubber based sealant.*

STARTING BATTERY

The generator set must have sufficient cranking power to the starter under various operating conditions. Choose a battery and cables that are appropriate for the application and then devise an adequate battery compartment.

Battery and Cable Selection

The HDKAG generator set requires a 12-volt battery with a rating of 425 cold cranking amps. A larger capacity battery may be desirable if it is also used to power other coach accessories. Cummins does not recommend use of the vehicle starting battery for operation of the generator set. Doing so might discharge the battery under some operating conditions. Long lengths of battery cable may also be required depending on location.

For reliable cold weather starting, the voltage drop from the battery terminals to the starter terminal should not exceed 0.12 volts per 100 amperes of current. The starter motor draws (100) amperes at 12 VDC. Table 9-1 shows the recommended cable sizes for different cable lengths necessary for reliable cold weather starting to -20° F (-29° C).

TABLE 9-1. CABLES FOR COLD WEATHER STARTING TO -20°F (-29°C)

*CABLE LENGTH IN FEET (METRES)	CABLE SIZE
0-10 (0-3)	2**
11-15 (3-4.5)	0
16-20 (4.5-6)	000

* Distance from battery to set.

** For warm weather operation, #2 cable can be acceptable up to 20 feet (6.1 m).

Battery Compartment

House the battery in its own compartment, away from the generator set and any spark-producing device. The compartment must be properly ventilated with a minimum opening at the top and bottom of 1.7 in² (11 cm²) and in a location where leaks and accidental spills will not damage the generator set, fuel lines, and wiring.

⚠WARNING *Fire or explosion hazards can cause severe personal injury or death. Be sure to mount the battery in a separate compartment away from the generator set or other spark-producing device.*

Battery Connections

Be sure the frame connection (major frame member, if possible) is sufficient to minimize resistance. Try to avoid connection at a weld or mechanical joint. For short distances, one negative battery cable can be used between set and battery rather than separate cables to chassis ground.

The battery positive (+) terminal connects to the start solenoid (Figure 9-6). Connect negative battery cable last. Use the same size cable to connect battery negative terminal to ground as used for battery positive. Be sure terminal connections are clean and tight.

⚠WARNING *Ignition of explosive battery gases can cause severe personal injury. Do not smoke while servicing batteries.*

⚠WARNING Sparks can ignite battery gases and result in an explosion and severe personal injury. Do not disconnect battery cables while generator set is cranking or running.

The belt-driven battery charge alternator has a maximum output rating of 33 amps. The actual output amperage depends on the battery state-of-charge and any load that may be connected.

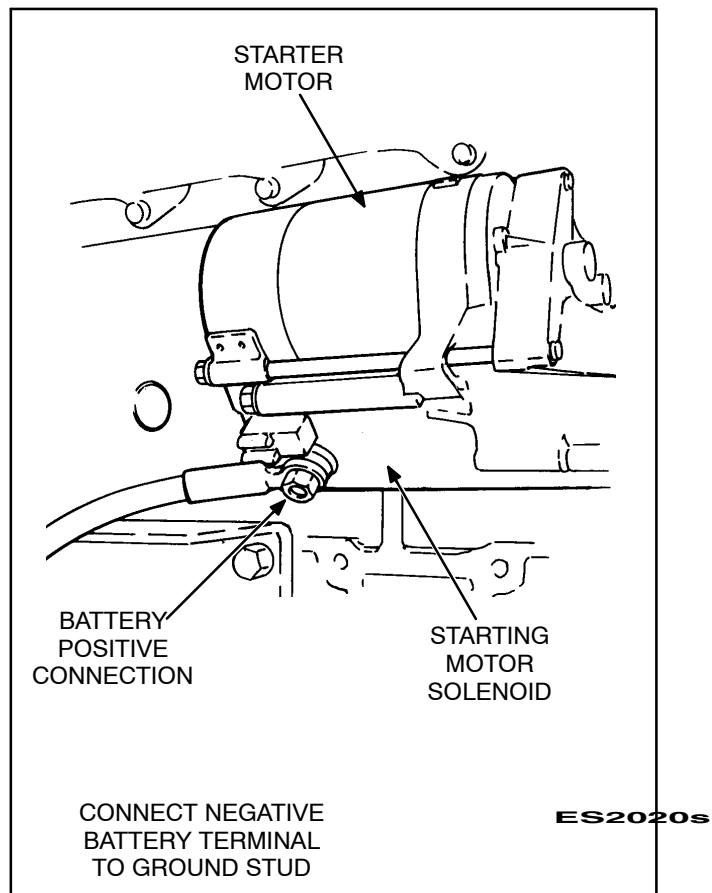

FIGURE 9-6. BATTERY CONNECTIONS

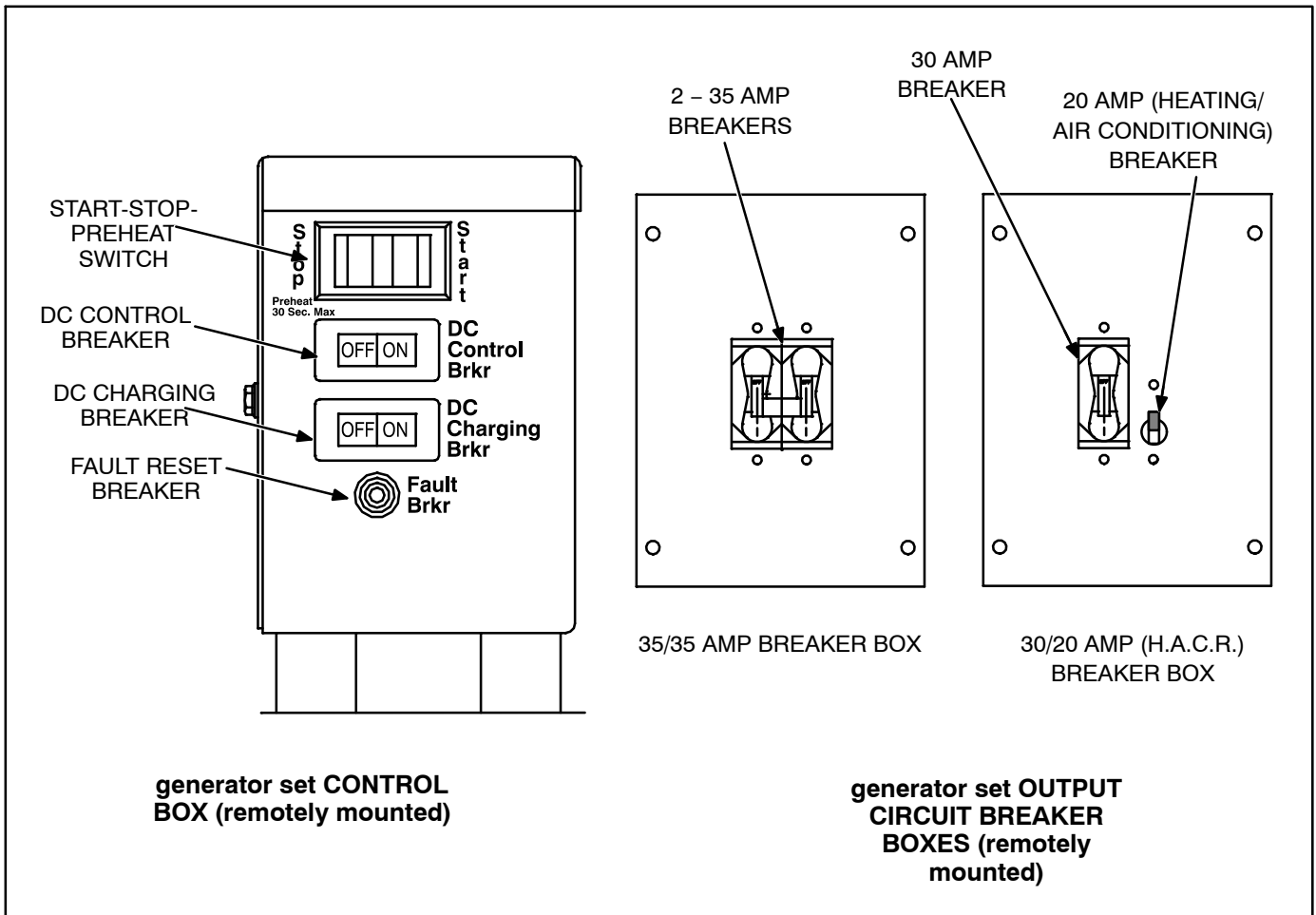

FIGURE 9-7. CONTROL BOX/BREAKER BOX FRONT PANELS

INSTALLATION OF GENERATOR SET CONTROL BOX

Control Box Location and Mounting

Locate the control box in an area that will not be contaminated by grease, oil, dust or dirt. A low-vibration area with maximum accessibility is the best location.

The control box must be mounted in an area with a temperature less than 160° F (71.1° C). Higher temperatures may damage the control.

▲ CAUTION *Failure to mount the control box in an environment with a temperature less than 160° F (71.1° C) may cause equipment damage or failure.*

Unscrew the bolts from the four vibration isolators (rubber mounting feet) that support the control box. Drill holes of the appropriate size and place the box

into position. Make certain that there is enough room to insert and remove the wiring harness connector plugs in the back of the control box (see Figure 9-8). Make certain that the generator set controls are easily viewed and readily accessible to the operator.

It is not mandatory that the vibration isolators be used. In a low-vibration environment, the generator set may be mounted directly to a surface without using the isolators.

However, if using the isolators, note the following:

The toothed washers (provided) must be mounted under the vibration isolators as shown in Figure 9-8. These washers, when mounted correctly as shown in the illustration, will prevent the vibration isolators from rotating. When the isolators rotate under pressure, they can deteriorate rapidly.

CAUTION *If mounting the control box with the rubber vibration isolators, use the toothed washers to make certain that the isolators do not rotate. Failure to follow this guideline may promote deterioration of the control box mounting, and subsequent equipment damage.*

Electrical Connection to Generator Set

The generator set is shipped with two long harnesses. After mounting the control box, plug the harness connectors into the control box. The J2 harness (see Figure 9-8) has the largest connector.

This harness conducts control and annunciation functions to and from the set. The J1 harness has a smaller four-conductor connector. This provides AC monitoring from the AC control box on the set.

Route the harnesses against the walls of the generator set compartment, mounting them so that they are out of the way and will not interfere with generator set operation. Make certain that the harnesses are kept away from sharp edges or heavy objects that could cut, fray, pinch or otherwise damage them. Neatly coil and store any excess harness length in a position where it is out of harm's way.

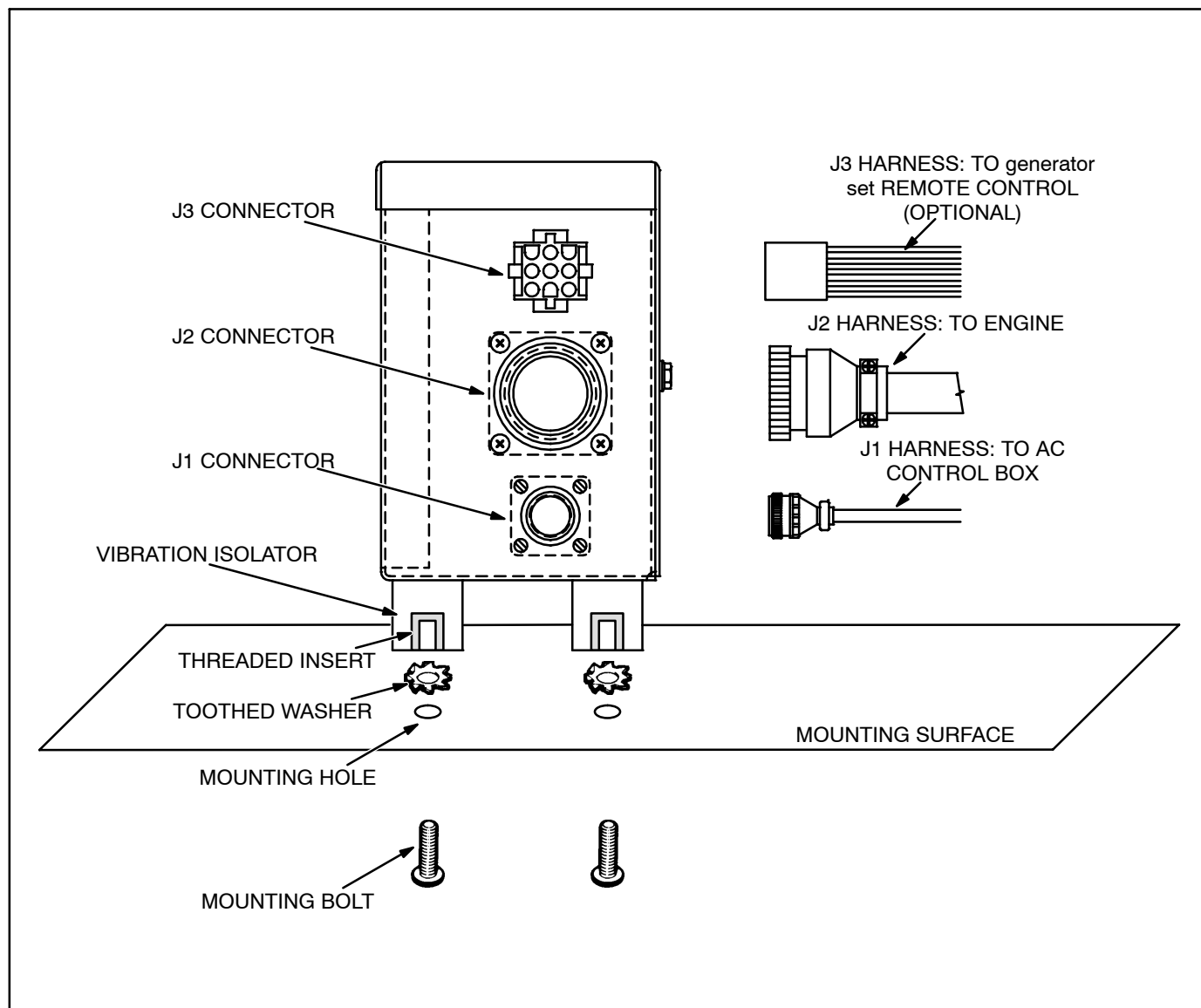

FIGURE 9-8. CONTROL BOX MOUNTING

Installation of Line Circuit Breakers in 50 Hz Generator Set

Line circuit breakers for the 50 Hz generator sets are sold separately as kits. The installer must mount and wire the the appropriate breakers for the required voltage into the generator set control box.

⚠WARNING *Electrical shock can cause severe personal injury or death. Use extreme caution when working on electrical circuitry. Incorrect connection of generator set output could lead to equipment damage, death or serious injury. Only a qualified electrician who is familiar with electrical wiring codes and grounding procedures should make this installation.*

1. If the generator set is not yet installed, go to step 6. Otherwise, go to step 2.
2. Park the recreational vehicle (RV) on as level a surface as possible.
3. Put the RV in park position, lock the brakes, and remove the ignition key. Make sure no one moves the vehicle during this procedure.

⚠WARNING *Movement of the RV could result in severe personal injury or death during this procedure. Make sure no one moves the vehicle during this procedure and that the procedure is performed very carefully and only as instructed.*

4. Disconnect the generator set starting battery ground (-) cable at the battery.

⚠WARNING *High AC voltage presents the hazard of severe personal injury or death. Be sure to disconnect the generator set starting battery ground cable to prevent accidental starting.*

5. Remove the cover from the generator set control box on the generator set.
6. Mount the circuit breaker assembly in the control box using screws and washers the held the cover plate (Figures 9-9 and 9-10).
7. Connect the generator output leads L1, L2, and L3 to the circuit breaker as illustrated on Page 11-4. The breaker is called CB22 on the diagram.
8. Run the RV neutral lead into the control box on the set. Connect it to the ground connection (captive screw in the side of the control box). Connect the generator set neutral lead on the ground connection inside the control box (captive screw in the of the control box).
9. Connect the green lead from the generator set and the green lead from the RV to the ground connection (captive screw in the side of the control box). Tighten the 1/4-20 screw down onto the leads connected to the ground screw in this step and the previous step.
10. Secure the conduit(s) to the control box.
11. Reconnect the generator set starting battery ground cable.

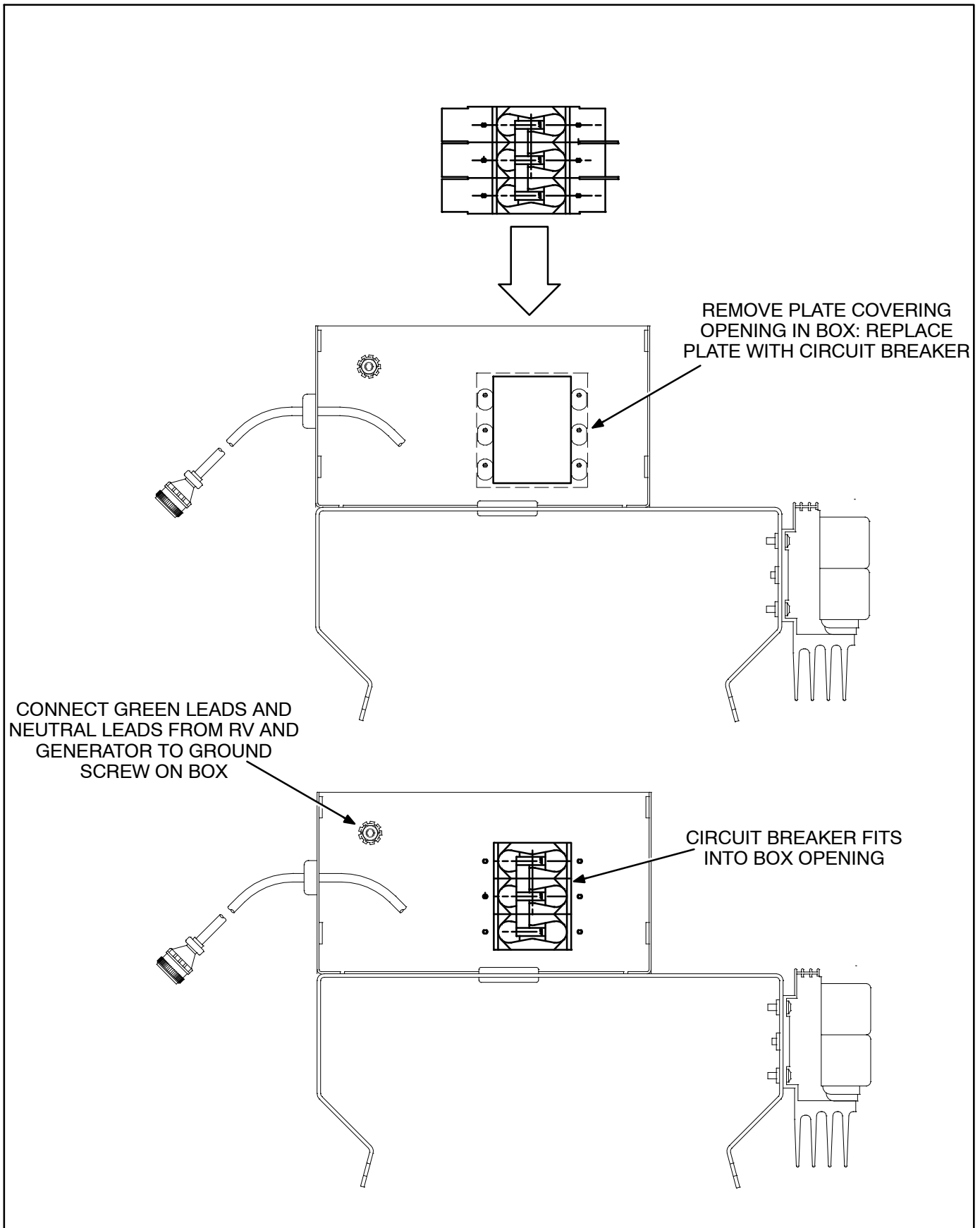
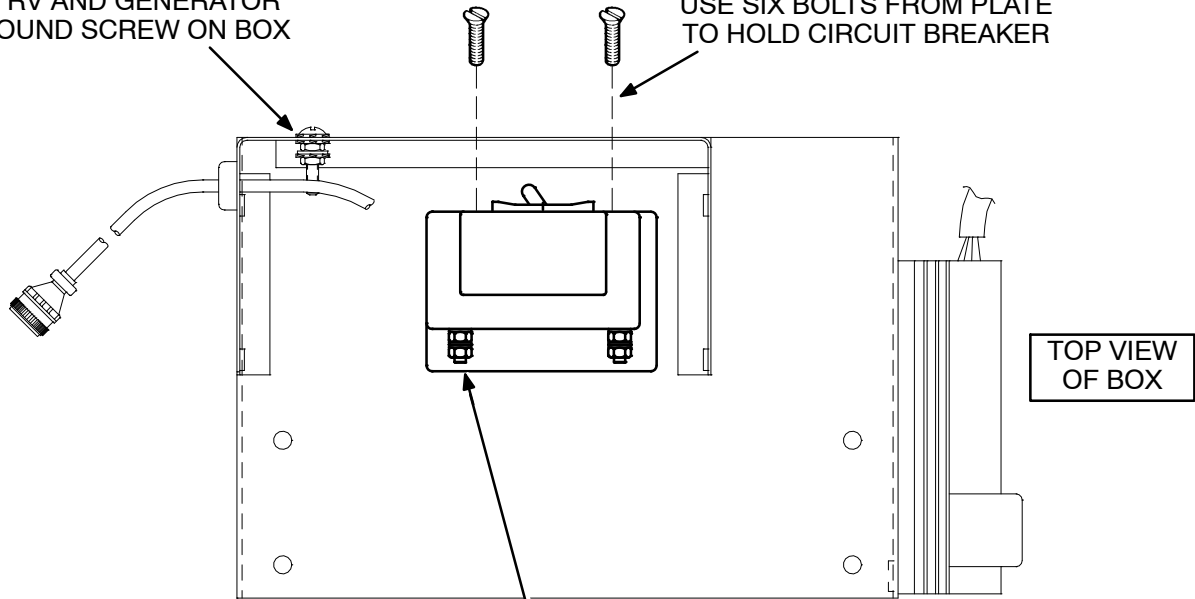

FIGURE 9-9. MOUNTING CIRCUIT BREAKER IN CONTROL BOX (1 of 2)

CONNECT GREEN LEADS FROM RV AND GENERATOR TO GROUND SCREW ON BOX

USE SIX BOLTS FROM PLATE TO HOLD CIRCUIT BREAKER



CONNECT L1, L2, L3 LEADS FROM GENERATOR TO BREAKER (SEE PAGE 11-4 [AC WIRING DIAGRAM])

LOAD

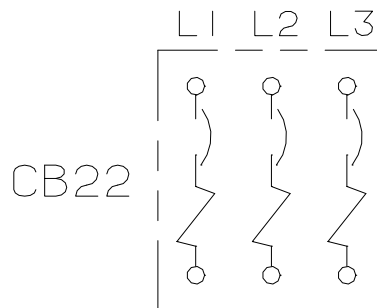

FIGURE 9-10. MOUNTING CIRCUIT BREAKER IN CONTROL BOX (2 of 2)

THIS PAGE IS INTENDED TO BE BLANK

10. Initial Start and Checks

INSTALLATION REVIEW

Before initial start up of the generator set, check (√) each of the following items. For a good installation, each answer must be **yes**: if not, that part of the installation should be reworked, or provision made to satisfy the requirement.

⚠WARNING *Incorrect installation, service, or parts replacement can result in severe personal injury, death, and/or equipment damage. Installing personnel must be qualified to perform electrical and mechanical component installations and service.*

- Is the compartment metal-lined and sealed around all edges?
- Are all fuel connections and hose clamps tight?
- Are fuel lines and electrical wires protected from chafing and damage and are they insulated from each other?
- Are wiring holes into the inside of coach (including the inside of AC conduit) sealed to prevent passage of exhaust gases?
- Are all electrical leads connected and protected, and is the conduit adequately supported?
- Are all openable windows, doors or storage compartments outside a triangle formed by a 2 foot base centered on the exhaust pipe with a height 3 feet? Refer to the *Exhaust System* section.
- Does the exhaust system extend beyond the perimeter of the vehicle a minimum of 1 inch (25 mm)?
- If the exhaust system is run into the angle of approach or departure (see Figure 6-1), is it protected from bottoming out by use of skid bars, rollers, etc.?
- Is the exhaust system secure and are all connections tight? Are all required exhaust clamps, hangers, and support straps in place per the *Exhaust System* section of this manual and the kit instructions?
- Are air inlet and exhaust openings clear and sufficiently sized (see *Mounting* section) for proper airflow?
- Is the generator set protected from direct road splash from vehicle wheels?
- Can the following routine maintenance items be performed through the vehicle access panel?
 - Change oil
 - Start/stop the unit
 - Change air filter
 - Access AC circuit breaker and control fuse
 - Access coolant fill and drain
- Has the crankcase oil been added to the engine and is the oil level correct?

⚠WARNING

EXHAUST GAS IS DEADLY!

Exhaust gases contain carbon monoxide, an odorless and colorless gas. Carbon monoxide is poisonous and can cause unconsciousness and death. Symptoms of carbon monoxide poisoning can include:

- **Dizziness**
- **Nausea**
- **Headache**
- **Weakness and Sleepiness**
- **Throbbing in Temples**
- **Muscular Twitching**
- **Vomiting**
- **Inability to Think Coherently**

IF YOU OR ANYONE ELSE EXPERIENCE ANY OF THESE SYMPTOMS, GET OUT INTO THE FRESH AIR IMMEDIATELY. If symptoms persist, seek medical attention. Shut down the unit and do not operate until it has been inspected and repaired.

Never occupy the vehicle with the generator set running unless the vehicle interior is equipped with an operating carbon monoxide detector. Protection against carbon monoxide inhalation also includes proper exhaust system installation and visual and audible inspection of the complete exhaust system at the start of each generator set operation.

1-RV

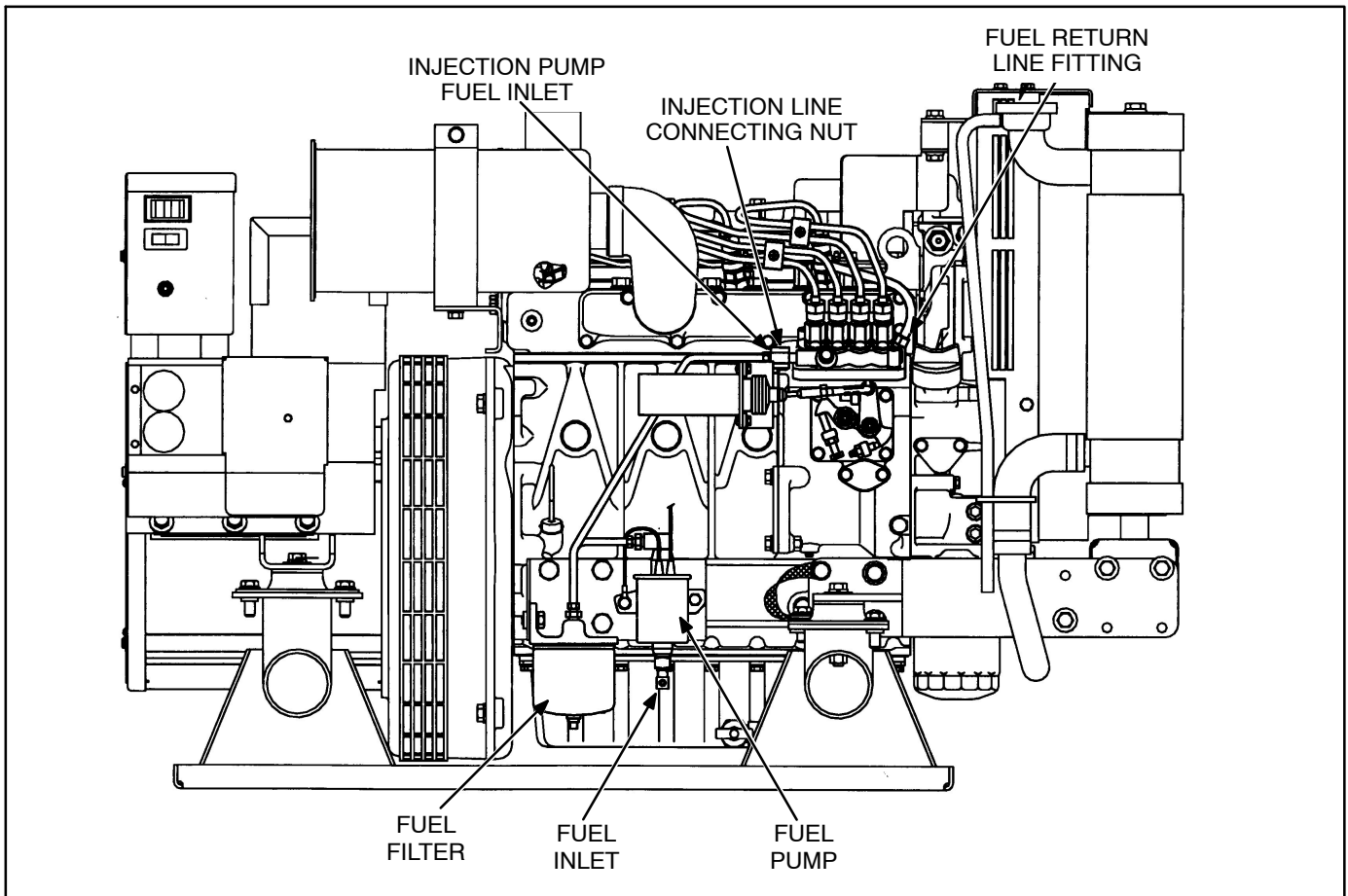

FIGURE 10-1. FUEL SYSTEM

INITIAL STARTING AND CHECKS

⚠ WARNING *Exhaust gas presents the hazard of severe personal injury or death. Do not operate the generator set inside any room or building.*

If none of the fuel line junctions have been loosened between the electric fuel pump and the injection pump, the fuel system should not need priming. However, if priming is necessary, it should be done according to the following procedure.

Priming the Fuel System

⚠ CAUTION *Priming the fuel system should only be done by a skilled and experienced diesel technician. Incorrect priming could lead to equipment damage or faulty operation.*

1. Disconnect the negative (-) lead to the generator set starting battery, to make certain that the generator set cannot be started.

2. Use clip leads to jumper B+ and ground to the electric fuel pump. Run the fuel pump for five to ten seconds until the air is purged from the low-pressure fuel system.
3. Reconnect the starting battery so that the generator set may be cranked.

If air still remains in the fuel system, further priming is necessary. This involves loosening the fuel system joints in turn, at the points between the electric fuel pump and the individual cylinder injectors shown in Figure 10-1, and operating the fuel pump to push the air out. **If further priming is necessary, consult a trained diesel technician or an authorized Cummins service center.**

Starting the Generator Set

1. Start the generator set by first holding the Start/Stop/Preheat switch on the engine control panel in the Preheat position for 15 to 30 seconds. Then hold the switch in the Start position. The engine should start within a few seconds.

2. Monitor the remote mounted engine control panel and note the oil pressure, coolant temperature, and battery charge voltage gauges (if equipped). Refer to the Operator's Manual for normal readings. At operating temperature, all readings should stay within the normal range.
3. Check the exhaust system for leaks, visually and audibly. Note the security of the exhaust system supports. If any leaks are found, shut down the generator set immediately and repair.

⚠WARNING Exhaust gas is deadly. For this reason, shut down the generator set immediately if you discover an exhaust leak or exhaust component needing replacement. Do not use the generator set until you have the exhaust system repaired.

4. Check the generator set for fuel, oil or coolant leaks. If any are found, shut down the generator set and repair leak before making any more checks.
5. Connect an accurate AC voltmeter and frequency meter across two line terminals. Apply load to the generator and check output voltage and frequency. The voltage can be adjusted per the following procedure.

⚠WARNING Generator output presents a shock hazard which can result in severe personal injury or death. Use caution when measuring output voltage and frequency.

Voltage Adjustment Procedure

When checking output voltage, be sure the generator set has stabilized and is running at the correct speed (frequency). The regulator is adjusted with the set running.

⚠WARNING Accidental starting of the set can cause severe personal injury or death. Disconnect both battery cables, negative (-) cable first, when repairs are made to the engine, controls, or generator.

⚠WARNING Contact with high voltage can cause severe personal injury or death. Do not touch any exposed wiring or components with any part of the body, clothing, tool or jewelry. Do not use non-insulated tools inside the control. Stand on an insulating mat or dry wood platform when the control doors are open.

⚠WARNING The voltage regulator settings are done at the factory. These generators are not convertible from 50 to 60 Hz operation: for this reason, do not change the 50/60 Hz setting on the regulator. Switching the voltage regulator selector switch from 50 to 60 Hz or vice versa can result in equipment damage and/or fire hazard that can lead to severe personal injury or death.

Output voltage adjustments are found on the voltage regulator board under the DC control box. A removable cover protects the board. See Figure 10-2.

1. Attach a voltmeter securely to the L1 and L2 leads.
2. Start the generator set and place a typical load on its output.
3. Use a flat-blade screwdriver to set the voltage adjust potentiometer for correct voltage.

For most applications, the ideal setting is 117 VAC measured at L1-L2 terminals. Retighten the locking nut when complete.

Note that the voltage adjustment pot on the voltage regulator board is a 10-turn potentiometer: it may take several turns to change the voltage noticeably.

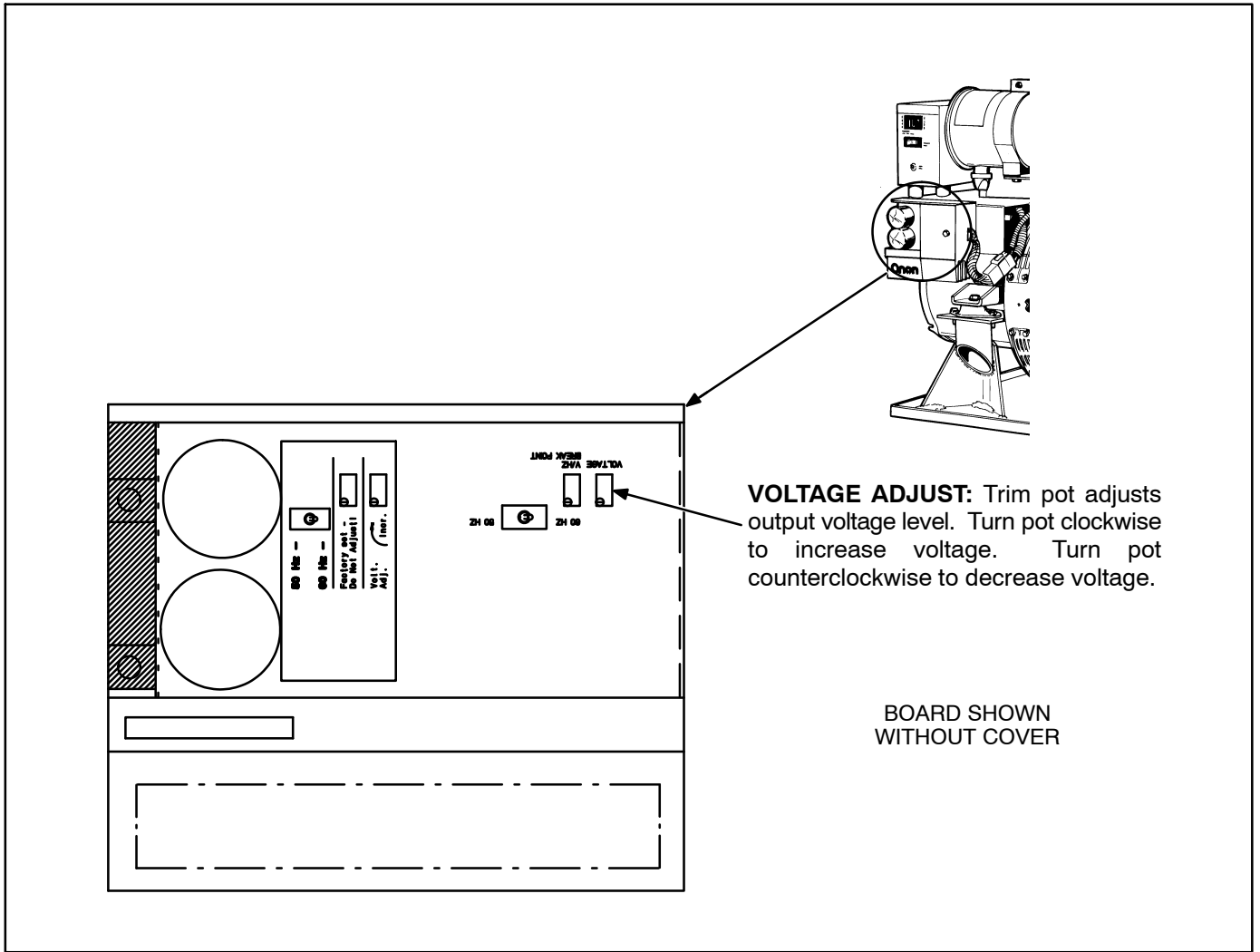

FIGURE 10-2. LOCATION, OUTPUT VOLTAGE ADJUSTMENT

THIS PAGE IS INTENDED TO BE BLANK

11. Wiring Diagrams

The electrical schematics and wiring diagrams that apply to the generator set covered in this manual are listed below.

WIRING DIAGRAM	DRAWING NO.	PAGE
DC Control Assembly	612-6635	11-2
AC Control Assembly (single-phase)	612-6637	11-3
AC Control Assembly (three-phase)	612-6732	11-4

Refer to these drawings when installing and maintaining the set.

THIS PAGE IS INTENDED TO BE BLANK

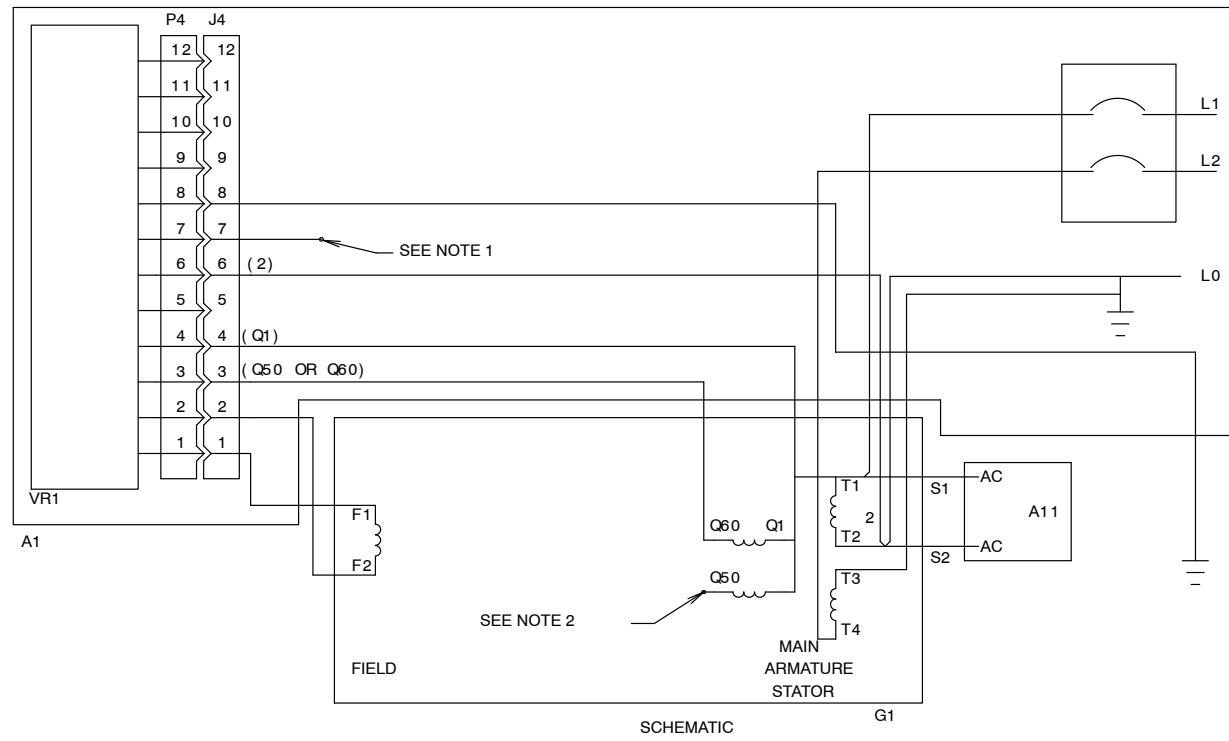

110/220V, 115/230V & 120/240V AS SHOWN
SEE RECONNECTI ON CHART FOR OTHER VOLTAGES

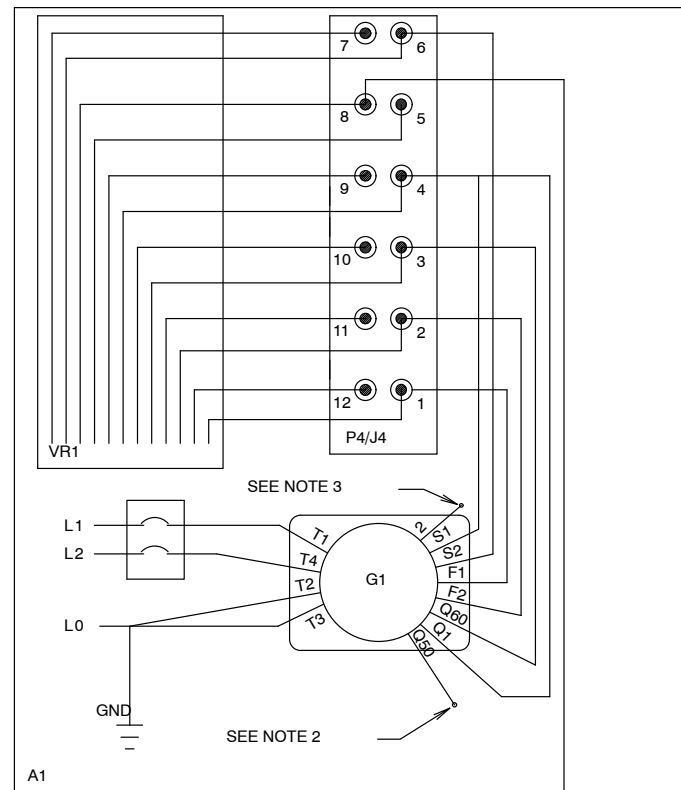

110/220V, 115/230V & 120/240V AS SHOWN
SEE RECONNECTI ON CHART FOR OTHER VOLTAGES

REF DES	PART NO	DWG SIZE	QTY	DESCRIPTION
1	---	---	1	WIRE HARNESS
2	---	---	1	LEAD (F1)
3	---	---	1	LEAD (F2)
G1	---	---	1	GENERATOR
VR1	---	---	1	VOLTAGE REG-CAP AVR

NOTE:

1. FROM J2-15 FOR FIELD FLASHING.
2. QUADRATURE POWER CONNECTION Q60-60 HZ, Q50-50 HZ UNITS.
3. AVR REFERENCE VOLTAGE.

	A	B	C	HZ	CODE
VOLTAGE	100 120	200 240	100/200 120/240	60	J
	110 115	220 230	110/220 115/230	50	P
SCHEMATIC					
DIAGRAM					

GENERATOR RECONNECTION CHART

AC WIRING DIAGRAM-ELECTRONIC REGULATION CODE L & Z

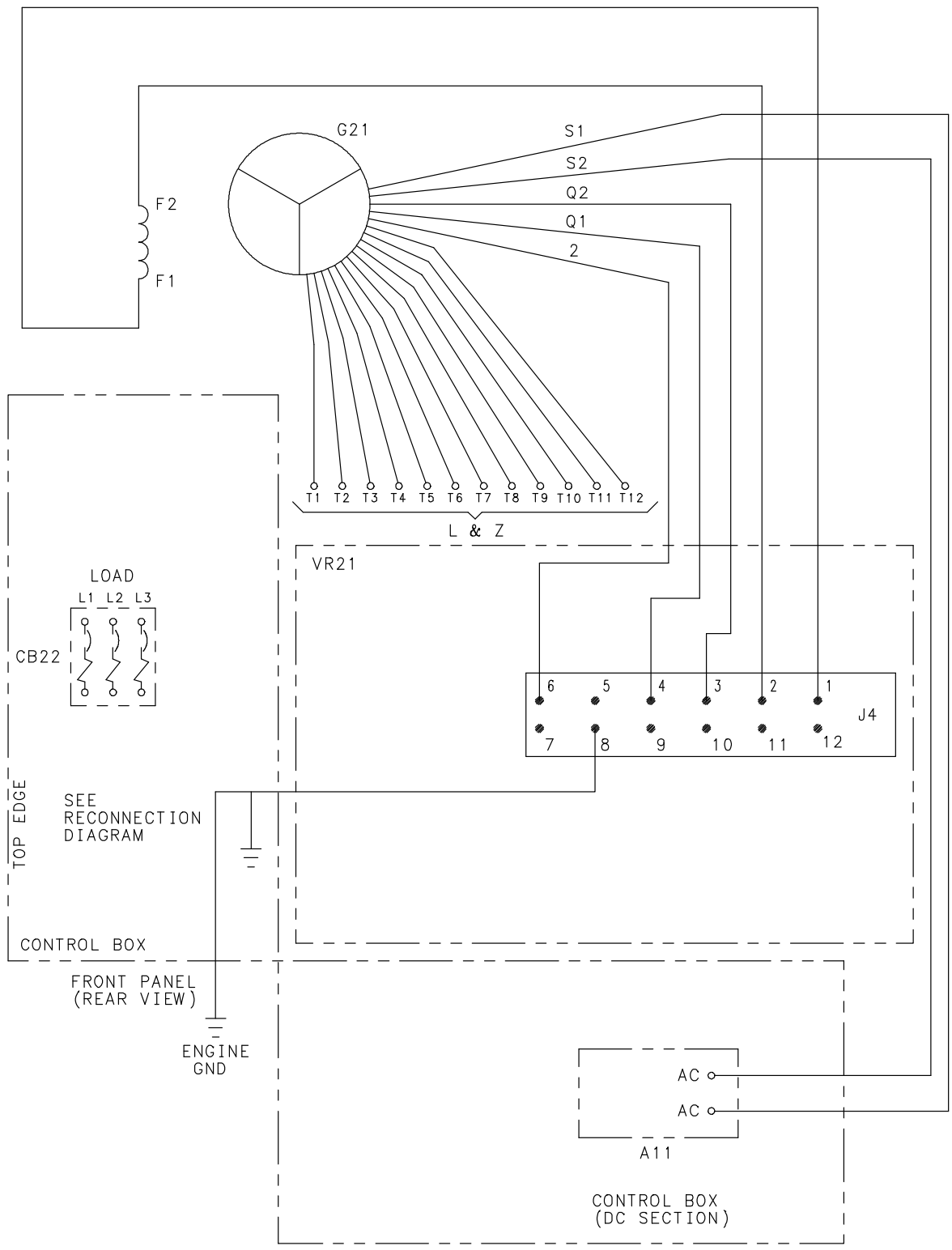

AC SCHEMATIC-ELECTRONIC REG VOLTAGE CODES (L & Z)

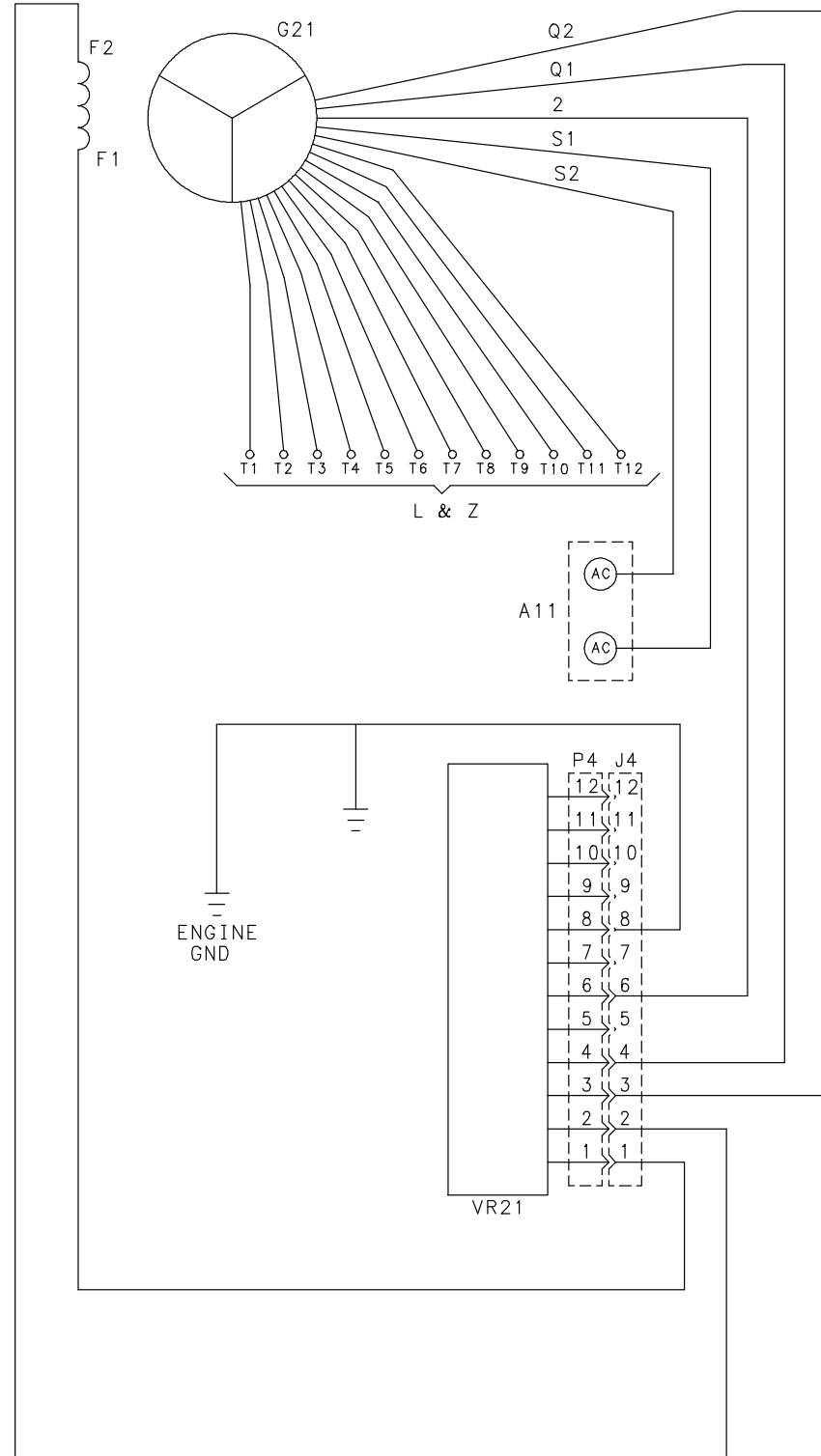

NOTE :

1. UNLESS OTHERWISE NOTED, ALL COMPONENTS ARE SHOWN IN DE-ENERGIZED POSITION.
2. DASHED LINES INDICATE CONNECTIONS WHEN USED.
3. INSULATE ALL UNUSED OR INTERCONNECTED GENERATOR LEADS WITH SLEEVING AND SECURE WITH CABLE TIE.

	MINNEAPOLIS, MINNESOTA 55432
	TITLE CONTROL-GENSET AC
	REV NO. 612-6743
SHEET 1 of 2	SIZE D

RECONNECTION CHART

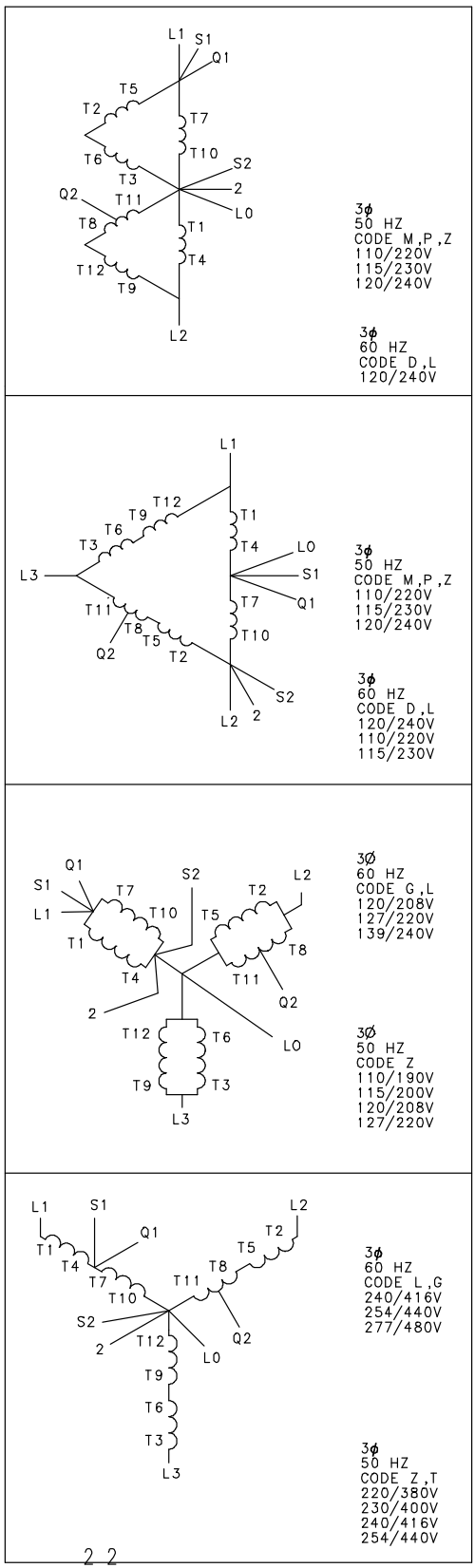

	MINNEAPOLIS . MINNESOTA 65432
	TITLE CONTROL-GENSET AC
ONAN NO. 612-6743	SHEET 2 OF 2 SIZE D

power.cummins.com

Copyright © 2018 Cummins Inc. All rights reserved.

Cummins, Onan, and the "C" logo are registered trademarks of Cummins Inc. and its subsidiaries.

Other company, product, or service names may be trademarks or service marks of others.

Specifications are subject to change without notice.

